

Review of Distributed Beamforming

Jason Uher, Tadeusz A. Wysocki, and Beata J. Wysocki

University of Nebraska-Lincoln, Omaha, USA

Abstract—As the capabilities of individual nodes in wireless sensor networks increase, so does the opportunity to perform more complicated tasks, such as cooperative distributed beamforming to improve the range of communications and save precious battery power during the transmission. This work presents a review of the current literature focused on implementing distributed beamformers; covering the calculation of ideal beamforming weights, practical considerations such as carrier alignment, smart antennas based on distributed beamformers, and open research problems in the field of distributed beamforming.

Keywords—*beamforming, distributed antenna array, smart antenna, virtual array.*

1. Introduction

With recent advancements in both size and power efficient computing, the concept of the ubiquitous wireless sensor network has quickly emerged as a legitimate research topic. It is now possible to have a large network of relatively small devices distributed over a large area, all with limited means of communications, and precious little power to spare for long haul links. Significant research has been done on efficient routing algorithms, mutual information coding, and multi hop transmission schemes in an effort to reduce the amount of power required to transfer sensor data from the individual nodes in a network to a final destination where the data can be used. In an effort to further reduce power consumption, the use of distributed phased arrays has come into focus as a method for nodes to collaborate in their transmissions, saving power overall during the data transfer. By cooperating, the nodes are able to emulate a traditional fixed array of antenna elements and achieve the same gains in terms of main lobe enhancement, side lobe reduction, and null pointing to improve the intended receiver's SNR and remove the interference caused by unwanted transmitters. These arrays are called distributed smart antennas, or distributed beamformers, and have their own unique set of problems over fixed beamformers when it comes to ideal weight calculations.

Use of the term "distributed" has two distinct meanings in the sense of distributed beamforming. The first meaning indicates that the antennas of the array themselves are distributed over the receiving plane in some randomly structured fashion. This is a departure from traditional beamforming literature, which relies on a strict, uniform placement of the antenna elements to reduce the complexity of the analysis through the removal of dependence on the in-

dividual locations of nodes within the arrays. When the nodes are no longer structured so nicely, the location of each element must be considered on its own, rather than simply considering the location of the array as a whole. In this scenario, the elements are still controlled by some central source; hence the locations, phase offsets, and transmit capabilities of each node are known quantities to be taken advantage of during ideal weight calculations.

The second meaning builds on the first, implying that the elements are not only distributed in terms of location, but are also independent processing units, such as with a wireless sensor network in a field. This second scenario severely limits the quantity and quality of information available to a beamformer. In this case, methods for determining ideal complex weights must distributed in the sense that they can be carried out by each node individually without sharing significant amounts of information. If the nodes were allowed to share the total amount of information about themselves, such as through some pre-communication phase, the second scenario would collapse into the first, where ideal weights could be calculated based on the global information and disseminated through the network by a single cluster head.

Early work with systems where the global parameters for each transmitter are known, but the transmission elements are not in an organized regular array allowed for an initial insight into how arrays of unfixed elements might be approached. When the elements are distributed as in wireless sensor network, new considerations can be added to the algorithms, taking into account the need for distributed processing and synchronization. Growing from there, the capabilities of randomly distributed networks with specific distributions can be analyzed in terms of their capability with respect to steering both peaks and nulls.

The remainder of this review is organized as follows: Section 2 presents early work performed in the area of unevenly distributed and randomly distributed antenna arrays and its application to modern distributed arrays. This groundwork paved the way for virtual antenna arrays in distributed wireless nodes, which are discussed in depth in Section 3. This section is focused on the ideal calculation of beamforming weights in distributed networks to achieve the ideal beam-pattern for broadcasting and reception. Section 4 covers the practical aspects of beamforming in a distributed network and the methods for using the ideal weights discussed in Section 3. Finally, Section 5 gives some open research problems in the area of distributed beamforming and smart antennas.

2. Early Work in Random Antenna Arrays

Due to the nature of original phased array systems, the concept of a distributed phased array was not something that was inherently obvious. As the topic grew from sonar and acoustics into the electromagnetic domain, it was seen as a given that arrays could be placed in specific patterns as dictated by a designer, there was just no need to analyze distributed or random arrays.

There was a small body of work, however, that focused on the properties of both non-uniform and random linear arrays; usually with the intention of decreasing the number of required elements, eliminating the need for individual amplitude control hardware, or analyzing the effects of placement errors when building a physical array. The first attempts at moving away from a strict linear array was presented in [1], which introduces the idea that elements in a linear phased array need not be evenly distributed over the length of the antenna. The main goal was the reduction of the number of elements, the author demonstrated that by placing the elements at arbitrary points along the line, the designer increases the degrees of freedom in the overall design because through the addition of location. The extra degrees of freedom allow for an increase in the capabilities of the array (while necessarily increasing the complexity of design). To reduce this complexity, [2] introduced the concept of an equivalent uniformly-spaced array (EUA), which reduces the non-uniform array to an equivalently driven uniform array with a chosen spacing. Building on these original papers, other researchers continued to develop the concept of non-uniform linear arrays, and new methods for the design and optimization of phased arrays were discovered. Initial mathematical models and descriptions allowed for the general construction of arrays with desirable properties, but left out optimization of specific parameters [3]. Further development of these models led to more practical design considerations such as sidelobe reduction [4], as well as some experimental verification of the models being derived [5].

With a strong understanding of the physical characteristics of non-uniform arrays in hand, researchers were able to build on the available models to generate theories based on random non-uniform arrays and how they behave statistically, rather than over a single iteration. Work included the analysis of general arrays [6], [7], the properties of the sidelobes [8], and even multidimensional arrays (disks and spheres) [9], [10].

3. Optimum Beamforming Weights

With the popularity of wireless sensor networks increasing steadily, there is now a need to further the analysis of arrays with truly random element spacing. Using the initial analyses from Section 2, especially those on multidimensional arrays [9], as a basis for the analysis of distributed beam-

forming in wireless networks allows researchers to apply the old concepts of fixed random arrays to wireless sensor networks.

Modern arrays benefit from a number of factors not available to the original body of research. First, the rapid advances in computers allow for fast, statistically significant numerical simulations, which allows potential schemes to be quickly evaluated. Second, increasing transmission capabilities allow for better control of arrays through the use of dynamic weighting. Arrays can now be weighted in software using complex weight multiplication, rather than cumbersome fixed phase and amplitude modifiers at the antenna elements themselves. With these improvements in technology, random array beamforming in wireless sensor networks bears only a slight resemblance to the previous work done on random arrays, but the initial research still provides valuable insight into the relationships between node placement and the achievable beam patterns.

The core of any modern beamformer is the complex weights used to modulate the signals at each element of the array in order to achieve the appropriate constructive and destructive interferences required for optimum results during cooperation. There are several problems unique to the calculation of ideal weights when beamforming using a distributed virtual array. The first change in weight calculation is clearly that the elements of the array are no longer in a fixed pattern, leading to extra complexity in the convergence of smart antenna algorithms. Additionally, it is possible that the elements may even be moving, introducing yet another factor in the calculation of ideal weights. This section focuses on the calculation of beamforming weights for individual nodes under these circumstances. In most cases, an ideal array of nodes is assumed; that is, the nodes have synchronized carriers and total knowledge of the array topology and source locations. When weight calculation methods deal with arrays where these assumptions do not hold, it will be specifically mentioned.

3.1. Distributed Beamformers as Wireless Relay Channels

At its heart, distributed beamforming can be modeled as a relay channel, with the transmitting nodes as sources, and the cooperative nodes as relays. It does not matter that often the sources and relays are the same node, or that every node may be able to reach the receiver on its own; the analysis is still pertinent in terms of ideal weight calculations. In this type of analysis, the definition of ideal may be flexible, meaning maximum gain at the destination, minimum power consumed, or minimum interference to unintended receivers. The benefit of this type of analysis is that little information about the array geometry or actual nodes is necessary, the network as a whole is abstracted, allowing generic analysis of performance under constraints on power consumption (weight magnitudes), available channel state information, and the number of cooperating nodes. The main drawback is that the geometry of the array, location of intended receivers, and location

of interferers is abstracted into the channel state information between the nodes, which is not always available or easily estimated. In addition, knowledge of the antenna geometry may alleviate a number of constraints that are artificially introduced in dependence on the inter node channels. The analysis is beneficial, though, as a fair comparison of theoretical ideal weight calculation methods for individual nodes. Relay channels are characterized by what they do to the message from the source node, such as amplify-and-forward (AF), decode-and-forward (DF), or filter-and-forward (FF); each with different challenges in terms of the presence of noise, algorithm complexity, and required node information. The most complex of these, in terms required information and potential sources of noise is the AF case; both the DF and FF network types are special cases of the AF network with constraints placed on the types and placement of noise and the complex weights used to amplify the signal. Figure 1 shows an example of

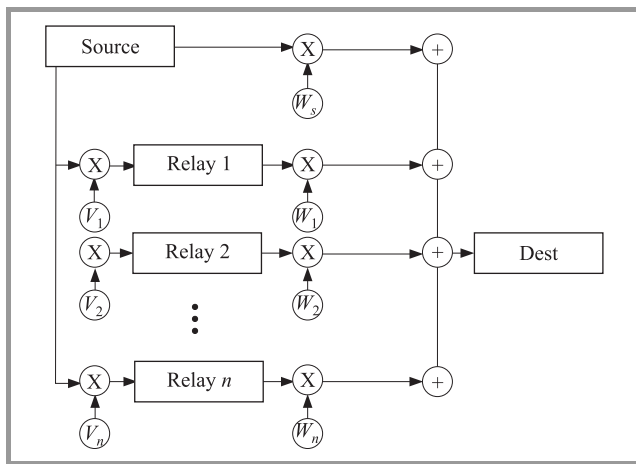

Fig. 1. Sample relay network.

a relay network with noisy channels and individual node weights. Due to the abstract nature of relay channels, and their application across a wide variety of domains, there exists a large body of work devoted to their analysis. When applied to distributed network beamforming, several limitations in traditional relay channels are added into the problem. First, it is not typically assumed that the transmitting node is involved in the cooperation to reach the receiver, in distributed network beamforming the transmitter is usually part of a cluster, and takes part in the transmission. Second, typical solutions rely on a single constraint, the quality of the link the receiver. This has the effect of creating a maximum main lobe towards the intended target, but gives little consideration to the rest of the beam pattern generated by the cooperating nodes. Additional constraints, such as minimizing the side lobes or steering nulls towards unintended receivers, add complexity to systems that already require significant relaxations to reach closed form solutions. As such, these systems may not be useful in practice due to the extreme complexity of the solutions.

Useful coverage of relay networks with respect to beamforming and beamcoding would warrant more coverage than this paper is capable of providing. As such, the remainder of the section will only provide a brief introduction on relay network methods with specific application to distributed beamforming, e.g. calculating ideal transmission weights to overcome channel effects, with a specific example of a paper with good coverage on that topic. To begin, [11] presents an excellent introduction to application of relay networks with respect to beamforming. It gives excellent examples of the workflow used when analyzing relay network beamformers. First, the constraint is chosen, in this case the SNR at the receive nodes, however any quantifiable quantity can be chosen, such as the capacity of the total link, the total power consumption, the per-node power consumption, etc. Second, an analytical derivation for the optimized value of interest is created based on the relay network model, and a method for iteratively reaching that optimum is presented. Finally, the problem is broken up such that the transmitter or receiver (or both) can calculate a single coverage parameter that leads the individual nodes to find their own optimum weights, distributing the calculation over the network. Here, basic AF and DF networks are analyzed with in terms of maximizing the SNR at the receiver based on varying degrees of channel state information, as shown in Fig. 2. For application to cognitive

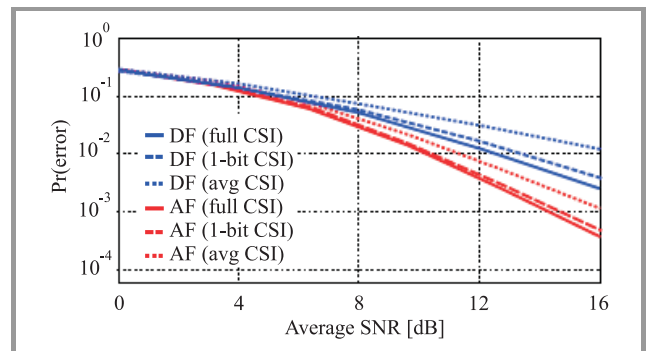

Fig. 2. Error analysis of DF and AF networks [11].

radio, it is possible to treat the relays such that there are multiple transmitters and receivers (either paired, or in one-to-many configurations), such as in [12]. This allows maximization of the constraint at each pair of nodes communicating through the relay. Additional constraints may be added to reduce the interference to primary users of a channel. In most cases, channel state information is a required piece of information (due to the lack of node geometry information). It is possible, however, to overcome this utilizing the relay network model, which utilizes the second order statistics of the channel, allowing for a more distributed approach.

3.2. Adaptive Distributed Arrays

When a target is moving, or ideal weight calculations are not possible due to lack of information, an adaptive

method may be used to home in on ideal weights by iteratively changing the phases based on the array performance. This leads to distributive smart antennas; capable of compensating for movement within the array, target or interferer as well as other changes in the channel.

In order to arrive at the ideal weights without full CSI, [8] attempts to iteratively find the optimum weighting at each relay using one bit feedback from the destination node. Two methods of iteration are introduced which randomly perturb the weights based quality information fed back from the destination node. The first method, take/reject perturbation (T/R), the weight is either perturbed or not based on the feedback; that is, if the receiver feels that the signal is sufficient, there is no perturbation. If the weights are to be changed, the perturbation new value is chosen such that

$$\tilde{a}'_k = a_k + \mu q_{k \bmod N},$$

where μ is a scaling factor which affects the rate of convergence and q_k is a preset value from the perturbation set q .

Utilizing T/R allows for constant improvement in the quality of the weights, that is, the quality of the overall link in each successive iteration is at least as good, or better, than the previous iteration. However, this method will be slow to converge, as it is possible that the quality may remain constant over several iterations. In the second method, plus/minus perturbation, the next weight is perturbed twice during transmission, and the feedback bit specifies which of the two was the best. In this case, the tested perturbations are

$$\tilde{\alpha}_k^{\pm} = \frac{\alpha_k \pm \mu q_{k \bmod N}}{\|\alpha_k \pm \mu q_{k \bmod N}\|}.$$

The additional values allow for a faster convergence to an ideal weight vector because there are twice as many perturbations available in each iteration. However, it may also be the case that neither α^+ or α^- are better than the old weight α_k , leading to worse performance in the immediate time window. In both cases, the calculation of the perturbations needs to be normalized by the weights of the entire array. Because this would require each element to share

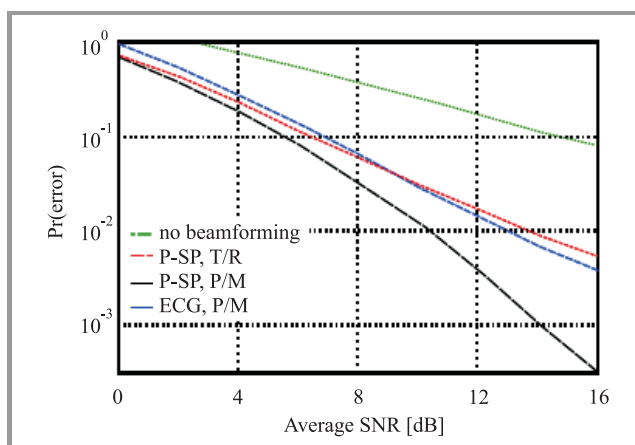

Fig. 3. Comparison of perturbation feedback schemes.

its random weight with the entire array, a method of deterministic perturbations is introduced which allows each of the relay nodes to calculate its weights independently of the others. Figure 3 shows a BER comparison between each of these schemes under fading conditions along with a traditional ideal weight method that require full knowledge of the CSI based on gain equalization. Modifications to this scheme in [9] show that utilizing multiplicative perturbations rather than additive can give an increase in the performance of the system due to the fact that the deterministic multiplicative perturbation set Q can be chosen such that a set phase rotation is applied regardless of the current weight value. In this case, the weights are perturbed as such

$$\tilde{a}'_k = a_k + Q_{k \bmod N}.$$

Figure 4 demonstrates the benefits of this method versus additive perturbation. Each perturbation moves the weights closer to their ideal values, as the multiplication prevents perturbation magnitude in irrelevant dimensions. In [13], the authors show that optimum beamforming weights can be found iteratively by having each node broadcast an effective cost to the other nodes in terms of its own interference. With of an idea of how its transmissions affect the other users, a single node can maximize its utility (data rate) while minimizing its interference to the other nodes. In addition, the updates of the users cost are distributed throughout many frames. In fact, when the costs are updated simultaneously, it causes oscillations and prevents the nodes from converging on an optimal solution.

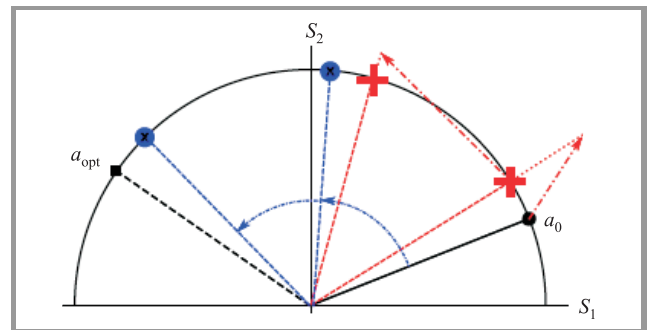

Fig. 4. Multiplicative versus additive perturbations [14].

A common relay channel technique is to use singular value decompositions (SVD) to obtain ideal beamforming weights using global CSI information. The SVD method allow the transmitter to precode data (x) sent over a MIMO channel (h) with the left decomposition of the channel (v) and the receiver to decode with the right decomposition (u), giving the received vector (y)

$$y = u^H H v x + u^H n.$$

The authors of [15] present an iterative method for calculating the right SVD vector, relying on blind adaptive methods for calculation of the left. This method works by treating the multiple paths as parallel SISO links with gain

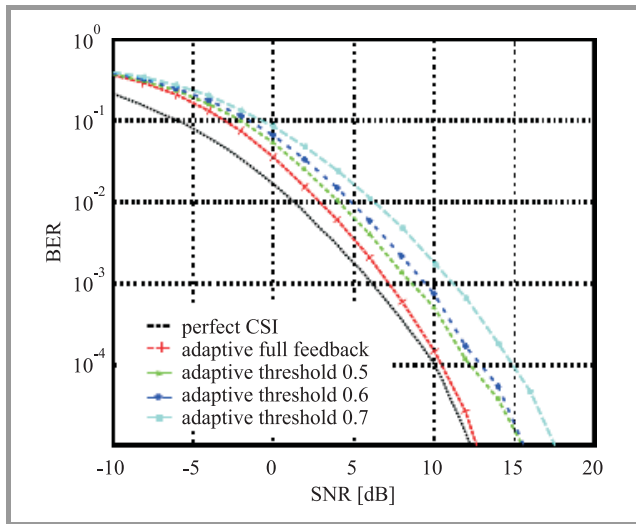

Fig. 5. Effects of feedback threshold on SVD weight calculations [15].

specified by the diagonal elements of the SVD, allowing nodes to calculate their ideal weights based on their local element. The amount of information sent over the feedback channel is reduced by using a predictor to estimate the value of the current singular vectors at each transmitting node, rather than feeding back the vector in each iteration. After each iteration of the transmission, the values of the singular vector are transmitted back to the relay if the difference between the estimated values and the calculated values exceed a set threshold, allowing for a balance between performance and the overhead in the control channel. In Fig. 5, the BER performance for varying thresholds is shown.

3.3. Distributed Weight Calculation

The greatest overhead in distributed beamforming is the sharing of locations or channel state information between the nodes to allow for weight calculations across the network. Methods for calculating these weights in a distributed fashion, sharing as little data as necessary, allow for vast improvements in the overall performance of the distributed arrays; making it one of the most important research topics in the field.

The best way to prevent the need for sharing CSI for every node is to not use CSI during the weight calculations. The authors of [16] present a system that uses the second order statistics of the individual node channels. Starting with an initial estimate of ideal weights, the individual nodes can continue to refine their own weights locally using only a parameter based on the combination of the transmissions in the uplink, which is fed back from the receiver. This idea is carried forward in [17], where the second order statistic calculation includes multiple source transmitter pairs, adjusting the weights at the relay nodes to optimize the signal at several receivers rather than just one, that is, the beamformer adjusts to minimize the transmit power (P_T)

subject to the required SNR between each transmit/receive pair

$$\min_w P_T \quad \text{SNR}_k \geq \gamma_k \forall k,$$

where SNR_k is the SNR at each transmitter pair and γ_k is the minimum required SNR for that pair.

In this case the SNR is actually the signal to interference and noise ratio (SINR) as the signals from other pairs are treated as interference,

$$\text{SNR}_k = \frac{P_k}{P_{n_k} + \sum_{i \neq k} P_i},$$

where P_{n_k} is the noise at P_k and the sum term is the power at each of the other pairs.

Utilizing these constraints, we can find the optimal weights through the following minimization

$$\min_w w^H D w \quad \text{s.t.} \quad \frac{w^H R_k w}{w^H (Q_k + D_k) w + \sigma^2} \geq \gamma_k,$$

where R , Q , D , and σ^2 are the correlation matrix of the channels, the average of the complex paths, the diagonal values of R , and the noise variance. The authors of [18] take the less common route of constraining the energy per node as well as the total system power, but still uses common information transmitted back from the receiver; namely the maximum SNR capability (Γ_{opt}) and computed scalar channel statistics (ξ , β_{opt}):

$$w_i = \min \frac{\xi l_i}{1 + \beta_{\text{opt}} + \lambda_{\text{opt}} \Gamma_{\text{opt}} N_i} (h_i g_i)^*.$$

Here the common scalar channel characteristics taken in accord with the local values of the channel (h_i, g_i, N_i) allow the local node to compute its own value without sharing weights individually. The calculation of the common statistics, in particular Γ_{opt} , takes into consideration the transmission power at individual nodes. Figure 6 shows the performance of the systems as a comparison of

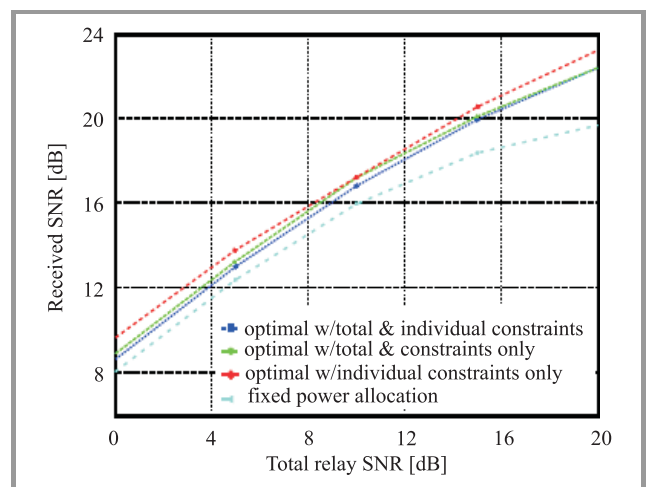

Fig. 6. Distributed beamforming constraints [19].

the SNR at the receiver dependent on the total SNR of the relay, the total transmit power divided by average noise power. It is clear to see that the per node power constraints allow for a higher SNR at the receiver when the overall SNR is low, but that when the links are of a higher quality, the total power constraint method is superior. In [14], a system for weight calculation is presented such that there will be one node whose impact is the greatest, and will transmit at full power, or at some value depending only on the local information at the node. This is based on traditional relay selection where only the best relay is chosen, and the others remain quiet to conserve battery power. However, rather than remain quiet, these other nodes can still contribute power based on their own channels. The scheme in [14] feeds back an indication to the nodes as to which of them has been selected as the optimal transmitter, the chosen node will transmit at full power as in the traditional relay selection schemes, but the rest of the nodes will also transmit with a small amount of power based on their own channels to the receiver. A distributed SNR balancing approach in [20] that finds ideal weights to balance the transmission capabilities so that the lowest SNR of the transceiver set is maximized within the constraints, that is

$$\max_w \min(SNR_1, SNR_2) \quad P_T \leq \tilde{P}.$$

Here the lowest SNR at the two receivers is maximized subject to the total transmit power of each transceiver and all the relays

$$P_T = P_1 + P_2 + \sum_{i=1}^N P_{ri}.$$

They find that in the optimal case, it falls out that the SNRs become balanced, that is, $SNR_1 = SNR_2$. The authors go on to show that the phases of the individual relay nodes are essentially irrelevant (they are always a static linear combination of the phases of the transceivers, and therefore do not change over time), and that the ideal weights depend only on the ideal amplitude α . With these simplifications, the optimization problem can be reduced to its distributed form, which is dependent only on local information (f_i, g_i, b_i) and scalar values transmitted over a common control channel ($\xi_1, \xi_2, \xi_3, \alpha^T b$).

$$\alpha_i = \left(\frac{|f_i|^2}{1 + \xi_1} + \frac{|g_i|^2}{1 + \xi_2} + \frac{\beta \xi_3}{(1 + \xi_1) + (1 + \xi_2)} \right)^{-1} \frac{b_i}{(\alpha^T b)}.$$

When an array is large, it is possible that only certain nodes will be selected to cooperate in the beamforming. Subsection 4.1 discusses this topic in length, but it is common to select nodes, which approximate a uniform array, and apply a least squares estimation to the weights to correct the non uniformities. In [21], the authors present a system that uses this method, with the weight estimation distributed over the nodes. Though the entire steering matrix is still needed to calculate the ideal weights, the processing involved with calculation of the matrix itself is distributed

over the nodes. A statistical method for distributed weight calculation is presented in [22] and discussed in the next Subsection 3.4, on statistical analysis.

3.4. Statistical Analysis

Because the nodes in a distributed array might be randomly placed, it is useful to look at the average beampattern capabilities of distributed virtual arrays. The assumption in this avenue of research is that given a large enough set of nodes, there will be some subset that is capable of performing at least as well as the mean, giving a strong set of design criteria for ubiquitous distributed networks where the number of possible nodes is very high. In [23], an initial analysis of the average beam pattern for a random array is presented. The array is uniformly distributed over a disc, and derivations for both the average and distribution of the achievable beampattern is presented. The properties of both the main lobe and first side lobe are investigated. They show that on a good distribution, the beampattern is capable of approaching a main lobe with gain N and a side-lobe with gain $1/N$ where N is the number of cooperating nodes. Specifically, the beampattern approaches

$$P(\phi) = \frac{1}{N} + \left(1 - \frac{1}{N}\right) \left| 2 \frac{J_1\left(4\pi R \sin\left(\frac{\phi}{2}\right)\right)}{4\pi R \sin\left(\frac{\phi}{2}\right)} \right|^2,$$

where J_1 is the 1st order Bessel function. The first $1/N$ term is the average sidelobe gain, and is the minimum of the average pattern, while the $(1 - 1/N)$ term contributes to the main lobe.

Figure 7 shows the average beampattern for a variety of scenarios with different disc sizes (R) and N_s . It can be seen that when N equals 16 and 256, the average side-lobes are equal to $1/N$ ($-10 \log_{10}(16) = -12.04$ and $-10 \log_{10}(256) = -24.08$ respectively). If the nodes are distributed in a non-uniform manner, the mean (and distribution) of the main lobe will clearly change. Gaussian distributed nodes have a smoother mean curve for both the main lobe [19] and side lobe [25] areas of their pattern.

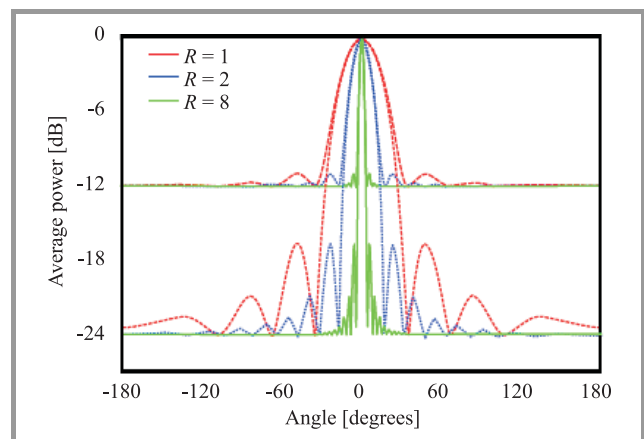

Fig. 7. Average beampattern for random networks [23].

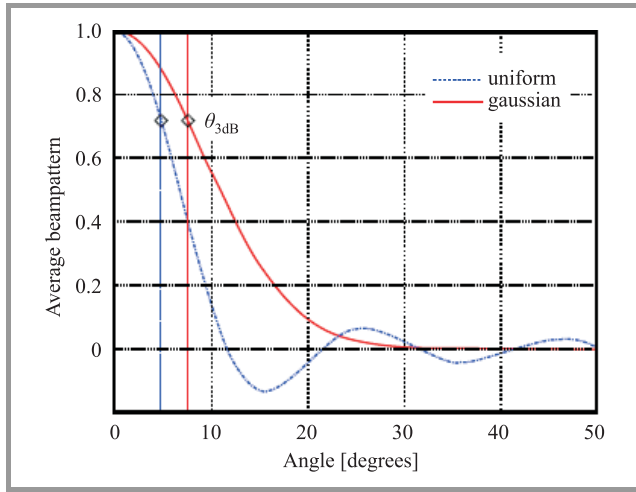

Fig. 8. Peak and sidelobe comparison [19].

This means that the Gaussian nodes have a wider main lobe, but the average pattern outside of the main lobe does not oscillate. Figure 8 shows a comparison of the average beampattern from a Gaussian and uniformly distributed random network. The smoother sidelobe achieved in the Gaussian distribution is clear to see, as is the wider main lobe. In comparison to the above equation, the average beampattern for the Gaussian network is

$$P(\phi) = \frac{1}{N} + \left(1 - \frac{1}{N}\right) \left| e^{-\frac{4\pi \sin\left(\frac{\phi}{2}\right) \sigma^2}{2}} \right|^2.$$

In this case there are no sidelobe oscillations from the Bessel function, only a smooth approach to the minimum. In [26], the authors extend the analysis of uniform distribution to include the concept of null steering, looking at the average interference rejection capabilities of distributed nodes without knowledge of the array geometry. Approximations for the locations of the other nodes based on their random distribution are used, and achieve similar performance results when the number of nodes is high due to the fact that the approximations are based on the values of the beamformer as that number goes to infinity. When nodes are mobile in addition to being randomly distributed, the ideal weights will change with time. In [27], the modeled beampattern from the preceding paper [23] is simplified to an ideal pattern where the gain is the maximum (N or N^2 depending on the arrangement) in the mainlobe beam width and the minimum ($1/N$ or N) everywhere else. The capacity of the network under this simplified assumption is derived and simulated as compared to a traditional pie wedge. The inclusion of the sidelobes in the approximation gives a better estimation of the capacity than the pie wedge. The authors of [28] present a method for determining the time required between updates when the nodes move with respect to a particular theoretical motion distribution. These models, based on the number of nodes and mobility distribution, can give guidelines based on the required fidelity at the receiver.

4. Practical Considerations in Distributed Beamforming

4.1. Node Selection and Placement within Virtual Arrays

The coordination of distributed nodes to find optimum weights for beamforming focuses on finding weights for every node cooperating in the solution, but it is not always prudent for every node in a network to cooperate in a given transmission. Often, a given subset of the network is capable of transmitting with the same quality as the entire network. Each extra node is using energy in the transmission, and is adding extra local overhead in the pre-transmission phase. In energy constrained wireless networks, this extra battery drain is unacceptable.

The topic of optimizing the size of a beamforming cluster is presented in [29], where the total energy for a cluster is calculated, based on the number of cooperating nodes. This paper presents an excellent introduction into the processes to take into account when selecting nodes for ideal power consumption. It is shown that there are an optimum number of cooperating nodes to obtain the minimum energy expenditure for the same quality of link. If the amount of power required to receive (P_R), transmit (P_T), and process a frame (P_{s1}) are known, then N nodes can collaborate using frames of length L_1 at rate R utilizing energy equal to

$$P_{col} = (2N - 3)(P_T + P_R + P_{s1}) \left(\frac{L_1}{R} \right).$$

During their responses of length L_2 , the nodes will consume

$$P_{res} = (N - 2)(P_T + P_R + P_{s1}) \left(\frac{L_2}{R} \right).$$

Finally, the nodes will collaborate to reach the destination by sending their messages, consuming a total of

$$P_{tot} = (P_T + P_R + P_{s1}) \left[(2N - 3) \left(\frac{L_1}{R} \right) + (N - 2) \left(\frac{L_2}{R} \right) \right] + NP_{s2} \left(\frac{L_2}{R} \right).$$

Because each of the variables is known, the equation can be minimized with respect to N , giving the least amount of required power to transmit the frame. This is shown to be convex and to have one global minimum. This is because when the number of nodes is small, the amount of required energy to reach the source per node is very high, but as the number of nodes increases, the energy cost of collaboration becomes prohibitive. In [30], the authors take a different approach. They provide a method for node selection with an emphasis on carrier synchronization. Although this topic is covered in depth in Subsection 4.2, those methods focus on synchronization of the selected nodes. In this paper, the authors select nodes based on their relative phases, rather than try to synchronize the phases directly. Nodes are clustered by their carrier phases to provide synchronized transmission, optimizing the selection criterion to maximize the received energy as opposed to

minimizing transmission energy. Because the phase offsets from some reference should be evenly distributed across all of the nodes, you will find that there are even numbers of nodes in each phase group, distributing the beamforming load across the entire network. In [31] the authors present a scheme that adaptively changes the number of beamformers to maintain the optimum ergodic capacity of the network. As channel information is fed back to the collaborating nodes, the overhead grows with the number of nodes. If this overhead is large enough, there will be an optimal number of nodes to participate in the beamforming process. The authors show that the capacity of a beamforming link is described by

$$C = \log_2 \left(1 + P_T \sum_{i=1}^N L_i \right),$$

where L_i is the large scale fading factor in the channel.

Utilizing the large scale fading factor from each node, the network can decide which users should be hindering the process, and selectively coordinate only the beamformers who increase the capacity at a given point in time based on their large scale fading factors. When nodes are chosen within an array for collaboration, they must be able to communicate with one another. As shown in [24], it is often the case that the ideal beamforming nodes will be out of communications range with one another, requiring the use of relay nodes and increasing the overhead of the node synchronization phase. By appropriately selecting nodes for beamforming based on their relative locations to one another, rather than solely on their fitness in terms of the desired beam, communications between the relay nodes can be maintained. If a specific area is required for the cooperative nodes in 4-order to maintain a good beam, the nodes from the edges of the necessary area should be chosen, providing a strong mesh network around the perimeter, rather than a loose network across the entire area. The achievable beam pattern of this randomly chosen group of nodes is similar to that derived in [26], however there is no longer the chance that an iteration of the random process will have nodes in the middle of the disc. As such, the new average beam pattern is equal to

$$P(\phi) \approx \frac{1}{K} + \left(1 - \frac{1}{K} \right) \left| J_0 \left(4\pi R_o \sin \left(\frac{\phi}{2} \right) \right) \right|^2,$$

where R_o is the outer radius of the disc.

This perimeter selection method is expanded upon in [26], where a series of concentric circles are chosen from the center outward to provide several strongly linked group of collaborative nodes with different capabilities in terms of possible main lobes and interference rejection based on the equation for $P(\phi)$ above.

Utilizing only certain nodes within a wireless sensor network to perform as a virtual array allows for a distribution of work to help prolong the life of a power constrained group of nodes. By finding the optimum number of beamformers and shutting down the transmission beyond the point of diminishing returns and by reducing the pre-

transmission overhead, the overall power consumption in these networks can be reduced in an effective manner.

4.2. Carrier Synchronization

With traditional beamforming systems, when each of the array elements are controlled by a single source, the carrier signal of each of the elements is assumed to be of the same frequency and phase, so the ideal weights calculated can make the necessary phase adjustments from the same baseline. Obviously, it is very difficult to assume that a distributed array of independent sensors in an array would have the same carrier phase across the whole network just by chance. Accommodations for the differences in the carrier must be made, either through direct synchronization of the carriers, or through changes in the calculated weights at each node. Though this problem is very important, indeed at the heart, of distributed virtual arrays; it is also important in a variety of applications in the wireless sensor network domain, including certain sensing applications, distributed space-time block coding, inter node relays, and timing applications. As such, there is a wealth of information regarding the carrier synchronization of nodes in a local distributed wireless sensor network. Because of this, a brief review of the carrier synchronization literature with specific applications to distributed virtual antenna arrays is presented.

The initial literature on distributed beamforming focused on the calculation of ideal weights for a non-uniform array, leaving the carrier synchronization of the nodes as a problem for the future. Paper [32] gives a general introduction to a two node beamformer which automatically adjusts the phase between the two collaborating transmitters so their transmitted symbols sum constructively at a receiver. A system is presented which allows the two nodes to synchronize via master slave architecture, and to "precode" their transmissions with a measured channel response, what we would call beamforming weights. This is a good general model for carrier synchronization in a distributed beamforming system, and is a theme that is often repeated. In [33], a test bed was built to monitor the performance of distributed acoustic beamforming for locating sources of noise. This initial, practical implementation showed the potential success for distributed beamforming without perfectly synchronized carriers, the authors of [34] and [35] sought to provide an analytical estimation of the limitations that distributed beamforming systems might see from unsynchronized carriers. When a reference carrier is transmitted from a master node, the effects of different phase differences are summed in the received carrier

$$u_i(t) = \cos(2\pi f_0 t + \theta_o + \theta_e(i)) + n_i(t),$$

where θ_o is the static offset between the carriers, θ_e is the error in the phase due to transmission and placement errors and n is the transmission noise.

Both analytical and numerical results were presented for a master-slave architecture in which cooperating nodes lock

their carriers to a master based on the received carrier $u_i(t)$. Each of the slave nodes is then able to adjust its own carrier based on this received waveform and the known distance between the two nodes. Guidelines are also presented as to the limitations of such a system when there are estimation errors in the received carrier and measured inter nodal distances. Paper [36] introduces a system in which a copy of the carrier is transmitted continuously from a each of receiving nodes, who merge their carriers on this distributed reference, requiring a significant amount of additional hardware at each cooperating node. Improvements to [36] are implemented in [37], where the number of required transmitting beacons was reduced (along with hardware complexity). This reduction comes in the form of carrier transmissions over time slots, effectively turning the carrier synchronization beacons into TDMA users who share the channel to broadcast their carrier information. With only a single bit a feedback from the receiver, an iterative approach to carrier synchronization can be carried out [38]. The authors introduce a system where the nodes are synchronized through the difference of groups of phases. In each iteration, nodes are assigned randomly to one of to groups, which transmit their data sequentially. The aggregate phase difference is calculated and transmitted to the second group, who update their own phases by this correction factor. After each iteration, the total synchronization of the entire set is closer than it was before. In comparison to the individual random perturbation scheme from [39], the pair wise updating method converges much more quickly, though it requires extra feedback information. By restricting the random search space, the new algorithm will converge quickly, but will not necessarily be able to guess the correct phase in a single iteration. However, because such feat has a very small probability anyway, so restricting the space leads to an overall improvement. Analysis and simulations include the performance gains when the search space (possible offsets) is restricted to a particular probability distribution, as well as the implementation of the algorithm on software-defined radios. Rather than attempt to synchronize the carriers of cooperative nodes at all, [40] presents a method in which the unsynchronized carriers do not matter. By having the cooperating nodes simply repeat each symbol several times, there will be a point when the carriers constructively interfere naturally, which can be detected at the receiver. Analysis of the number of repetitions required based on the number of cooperating nodes is presented, and numerical results show that the probability of alignment, and hence the number of repetitions required, reaches a steady state point for a specified number of cooperating nodes.

Though carrier synchronization is necessary in order to perform optimum beamforming in distributed networks, the preceding papers have shown that the problem is not as daunting as it seems. Through various combinations of data sharing between nodes, feedback from the end sinks, and statistical analysis of the networks the carrier synchronization problem is not insurmountable. Further research into

optimum methods for carrier synchronization can only improve the quality of beamforming in distributed networks, but the problem is well defined.

5. Future Work in Distributed Smart Arrays

Though the topic of distributed smart arrays has been studied from a high level to ensure that appropriate complex weights for individual nodes can be calculated optimally, the high level approach leaves significant gaps in the path toward utilizing DB in a non-coherent application like a wireless sensor network. Before DBF can be used in systems such as wireless sensor networks, personal area networks, and even mobile phone networks, further research into what might be physically capable by these networks is needed. The topics below present a brief cross section of some of the open problems in distributed beamforming that are available to researchers in the wireless communications field.

5.1. Achievable Beampatterns

In the current body of distributed smart array work, most attention is focused on the maximum achievable extension of the main lobe, and methods for steering that main lobe towards an intended receiver while directing nulls in the directions of interferers. A virtual array created from a wireless sensor network will have a significant number of elements available to it. This should allow for a beam-pattern that is capable of multiple beams and nulls. The capabilities of randomly distributed arrays in terms of amplifying and nullifying multiple incoming sources is a topic that would have strong applications, as a network rarely needs to interact with a single sink, or a single source of interference.

5.2. Cognitive Radio

As the ubiquity of sensor networks grows, so will the chance of utilizing bandwidth in an area where it is already assigned to some other entity. Cognitive radio attempts to diminish or eliminate interference with the primary of a particular channel and insert secondary communications into the spaces between primary transmissions. A virtual array should be able to find an ideal set of weights that can be used to eliminate interference at the primary user's location allowing the array to communicate at the same time as the primary user. Further investigation into the applicability of distributed phased arrays for the purposes of cognitive radio is essential to allowing wide spread operation of sensor networks in densely populated areas.

5.3. Heterogeneous Node Types

If distributed arrays are to be expanded beyond the scope of wireless sensor networks and be applied in other net-

work types such as a personal area network (PAN) or a group of military units, the assumption of identical cooperating nodes must be dropped. For example, a deployed group of soldiers may form a network between themselves, a local radio relay, and support vehicles. Each of these types of units will have a different antenna type on their equipment and different capabilities in terms of constraints on maximum transmit power, which is something not considered in the current body of literature. Further investigation into the cooperation of multiple node types can lead to distributed smart antennas in networks where it is currently considered impractical, and research into the methods for optimizing these heterogeneous networks will allow them to operate longer, possibly even longer than a similarly sized homogeneous network. Additionally, investigation into the situations where a homogeneous vs. heterogeneous group of contributors would perform better will lead to an advantage when designing systems that use distributed smart antennas. For example, it may be beneficial for a designated cluster head in a network to have a different antenna type than the cooperating radiators to optimize the radiation pattern of the virtual array.

5.4. Number of Cooperators

The current body of research into distributed smart arrays focuses on networks of either many, many nodes that all cooperate at once, or limited groups that take turns cooperating. Little attention is paid to the number of nodes in a beamforming array; for example, it is highly likely that there is a rule of diminishing returns in distributed arrays, where adding extra cooperating nodes will not provide an adequate performance gains to justify their power expenditure. Research into the optimum number of nodes to balance the power usage with the desired beampattern will allow networks to prolong their battery life by limiting the amount of unnecessary power expended. Additionally, research into adaptive algorithms capable of dynamically adjusting the number of cooperating nodes required to reach a receiver could maximize the efficiency.

5.5. Channel Estimation

Though the topic of channel estimation between two wireless radios is well researched, there may be benefits to be derived from estimating several channels in a distributed array environment. Given a sufficient distance between the information sink and the network, the channels between the sink and each node should be similar. It may be possible to find new ways to estimate the channel between the sink and each node in a distributed fashion, such as finding an average channel for the virtual array, and then deriving the individual channels from the average based on the known topology of the network.

5.6. Carrier Synchronization

By far, the largest roadblock to distributed antenna arrays is synchronization of the cooperating nodes. There has

already been headway into this area, but further research into not only methods of synchronization, but the effects of unsynchronized carriers, is necessary to ensure that the theoretical research into distributed arrays can be applied to its fullest.

References

- [1] H. Unz, "Linear arrays with arbitrarily distributed elements", *IRE Trans. Anten. Propag.*, vol. 8, no. 2, pp. 222–223, 1960.
- [2] S. Sandler, "Some equivalences between equally and unequally spaced arrays", *IRE Trans. Anten. Propag.*, vol. 8, no. 5, pp. 496–500, 1960.
- [3] A. Ishimaru, "Theory of unequally-spaced arrays", *IRE Trans. Anten. Propag.*, vol. 10, no. 6, pp. 691–702, 1962.
- [4] Y. Lo and R. Simcoe, "An experiment on antenna arrays with randomly spaced elements", *IEEE Trans. Anten. Propag.*, vol. 15, no. 2, pp. 231–235, 1967.
- [5] Y. Lo and S. Lee, "Sidelobe level of nonuniformly spaced antenna arrays", *IEEE Trans. Anten. Propag.*, vol. 13, no. 5, pp. 817–818, 1965.
- [6] A. Maffett, "Array factors with nonuniform spacing parameter", *IRE Trans. Anten. Propag.*, vol. 10, no. 2, pp. 131–136, 1962.
- [7] Y. Lo, "A mathematical theory of antenna arrays with randomly spaced elements", *IEEE Trans. Anten. Propag.*, vol. 12, no. 3, pp. 257–268, 1964.
- [8] M. Donvito and S. Kassam, "Characterization of the random array peak sidelobe", *IEEE Trans. Anten. Propag.*, vol. 27, no. 3, pp. 379–385, 1979.
- [9] A. Panicali and Y. Lo, "A probabilistic approach to large circular and spherical arrays", *IEEE Trans. Anten. Propag.*, vol. 17, no. 4, pp. 514–522, 1969.
- [10] P. Fertl, A. Hottinen, and G. Matz, "A multiplicative weight perturbation scheme for distributed beamforming in wireless relay networks with 1-bit feedback", in *Proc. IEEE Int. Conf. Acoust., Speech and Sig. Proces. ICASSP 2009*, Taipei, Taiwan, 2009, pp. 2625–2628.
- [11] M. Abdallah and H. Papadopoulos, "Beamforming algorithms for information relaying in wireless sensor networks", *IEEE Trans. Sig. Proces.*, vol. 56, no. 10, pp. 4772–4784, 2008.
- [12] Y. Zhang, X. Li, and M. Amin, "Distributed beamforming in multi-user cooperative wireless networks", in *Proc. Fourth Int. Conf. Commun. Netw. ChinaCOM 2009*, Xi'an, China, 2009, pp. 1–5.
- [13] C. Shi, R. Berry, and M. Honig, "Local interference pricing for distributed beamforming in MIMO networks", in *Proc. IEEE Military Commun. Conf. MILCOM 2009*, Boston, USA, 2009, pp. 1–6.
- [14] Y. Jing and H. Jafarkhani, "Beamforming in wireless relay networks", in *Proc. Inf. Theory Appl. Worksh.*, Petersburg, Russia, 2008, pp. 142–150.
- [15] C. Tsinos and K. Berberidis, "An adaptive beamforming scheme for cooperative wireless networks", in *Proc. 16th Int. Conf. Dig. Sig. Proces.*, Santorini, Greece, 2009, pp. 1–6.
- [16] A. El-Keyi and B. Champagne, "Collaborative uplink transmit beamforming with robustness against channel estimation errors", *IEEE Trans. Veh. Technol.*, vol. 58, no. 1, pp. 126–139, 2009.
- [17] S. Fazeli-Dehkordy, S. Shahbazpanahi, and S. Gazor, "Multiple peer-to-peer communications using a network of relays", *IEEE Trans. Sig. Proces.*, vol. 57, no. 8, pp. 3053–3062, 2009.
- [18] G. Zheng, K.-K. Wong, A. Paulraj, and B. Ottersten, "Robust and distributed beamforming", in *Proc. Int. Conf. Wir. Commun. Sig. Proces. WCSP 2009*, Nanjing, China, pp. 1–5.
- [19] M. Ahmed and S. Vorobyov, "Node selection for sidelobe control in collaborative beamforming for wireless sensor networks", in *Proc. IEEE 10th Worksh. Sig. Proces. Adv. Wir. Commun. SPAWC'09*, Perugia, Italy, pp. 519–52.
- [20] V. Havary-Nassab, S. Shahbazpanahi, A. Grami, and Z.-Q. Luo, "Distributed beamforming for relay networks based on second-order statistics of the channel state information", *IEEE Trans. Sig. Proces.*, vol. 56, no. 9, pp. 4306–4316, 2008.

[21] N. Papalexidis, T. Walker, C. Gkionis, M. Tummala, and J. McEachen, "A distributed approach to beamforming in a wireless sensor network", in *Conf. Rec. 41st Con. Asilomar Conf. Sig. Syst. Comp. ACSSC 2007*, Pacific Grove, USA, 2007, pp. 606–610.

[22] K. Zarifi, S. Affes, and A. Ghayeb, "Collaborative null-steering beamforming for uniformly distributed wireless sensor networks", *IEEE Trans. Sig. Proces.*, vol. 58, no. 3, pp. 1889–1903, 2010.

[23] H. Ochiai, P. Mitran, H. Poor, and V. Tarokh, "Collaborative beamforming for distributed wireless ad hoc sensor networks", *IEEE Trans. Sig. Proces.*, vol. 53, no. 11, pp. 4110–4124, 2005.

[24] K. Zarifi, A. Ghayeb, and S. Affes, "Distributed beamforming for wireless sensor networks with improved graph connectivity and energy efficiency", *IEEE Trans. Sig. Proces.*, vol. 58, no. 3, pp. 1904–1921, 2010.

[25] M. Ahmed and S. Vorobyov, "Performance characteristics of collaborative beamforming for wireless sensor networks with Gaussian distributed sensor nodes", in *Proc. IEEE Conf. Acoust. Speech Sig. Proces. ICASSP 2008*, Las Vegas, USA, pp. 3249–3252.

[26] K. Zarifi, S. Affes, and A. Ghayeb, "Distributed Proces. techniques for beamforming in wireless sensor networks", in *Proc. 3rd Int. Conf. Sig. Circ. Syst. SCS 2009*, Jerba, Tunisia, pp. 1–5.

[27] R. Harrington, "Correction to sidelobe reduction by nonuniform element spacing", *IRE Trans. Anten. Propag.*, vol. 9, no. 6, pp. 576–576, 1961.

[28] W. Lintz, J. McEachen, and M. Tummala, "Sensor beamforming with distributed mobile elements in a wireless sensor network", in *Proc. Canadian Conf. Elec. Comp. Eng. CCECE'09*, St. John's, Newfoundland and Labrada, Canada, 2009, pp. 323–328.

[29] P. Vincent, M. Tummala, and J. McEachen, "Optimizing the size of an antenna array", in *Proc. 14th Asilomar Conf. Sig. Syst. Comp. ACSSC'06*, Pacific Grove, USA, pp. 2281–2284.

[30] J. C. Chen, K. Yao, T. L. Tung, C. W. Reed, and D. Chen, "Source localization and tracking of a wideband source using a randomly distributed beamforming sensor array", *Int. J. High Perform. Comput. Appl.*, vol. 16, no. 3, pp. 259–272, 2002.

[31] N. Zhang, G. Kang, Y. Guo, P. Zhang, and X. Gui, "Adaptive transmitted distributed antenna selection strategy in distributed antenna systems with limited feedback beamforming", *Electron. Lett.*, vol. 45, no. 21, pp. 1079–1081, 2009.

[32] Y. Tu and G. Pottie, "Coherent cooperative transmission from multiple adjacent antennas to a distant stationary antenna through AWGN channels", in *Proc. IEEE Veh. Technol. Conf. VTC Spring 2002*, Birmingham, USA, 2002.

[33] J. Chen, K. Yao, and R. Hudson, "Source localization and beamforming", *IEEE Sig. Proces. Mag.*, vol. 19, no. 2, pp. 30–39, 2002.

[34] G. Barriac, R. Mudumbai, and U. Madhow, "Distributed beamforming for information transfer in sensor networks", in *Proc. Third Int. Symp. Inf. Proces. Sensor Netw. IPSN 2004*, Berkeley, USA, 2004, pp. 81–88.

[35] R. Mudumbai, D. Brown, U. Madhow, and H. Poor, "Distributed transmit beamforming: challenges and recent progress", *IEEE Commun. Mag.*, vol. 47, no. 2, pp. 102–110, 2009.

[36] D. Brown, G. Prince, and J. McNeill, "A method for carrier frequency and phase synchronization of two autonomous cooperative transmitters", in *Proc. IEEE 6th Worksh. Sig. Proces. Adv. Wir. Commun.*, New York, USA, 2005, pp. 260–264.

[37] I. Ozil and D. Brown, "Time-slotted round-trip carrier synchronization", in *Conf. Record 41st Asilomar Conf. Sig. Syst. Comp. ACSSC 2007*, Pacific Grove, USA, 2007, pp. 1781–1785.

[38] P. Jeevan, S. Pollin, A. Bahai, and P. Varaiya, "Pairwise algorithm for distributed transmit beamforming", in *Proc. IEEE Int. Conf. Commun. ICC'08*, Beijing, China, 2008, pp. 4245–4249.

[39] R. Mudumbai, J. Hespanha, U. Madhow, and G. Barriac, "Distributed transmit beamforming using feedback control", *IEEE Trans. Infor. Theory*, vol. 56, no. 1, pp. 411–426, 2010.

[40] A. Bletsas, A. Lippman, and J. Sahalos, "Simple, zero-feedback, collaborative beamforming for emergency radio", in *Proc. 6th Int. Symp. Wir. Commun. Syst. ISWCS 2009*, Siena, Italy, 2009, pp. 657–661.



Jason Uher holds the M.Sc. degree in electrical and computer engineering from Georgia Tech and is currently pursuing his Ph.D. at the University of Nebraska-Lincoln with a focus in wireless communications. His interests include MIMO block coding, polarization diversity, and heteroge-

neous beamforming in random antenna arrays.

e-mail: jasonuher@gmail.com

University of Nebraska-Lincoln

Omaha, USA



Tadeusz A. Wysocki (SM'98) received the M.Sc.Eng. degree with the highest distinction in telecommunications from the Academy of Technology and Agriculture, Bydgoszcz, Poland, in 1981 and the Ph.D. degree and the D.Sc. degree in telecommunications from the Warsaw University of Technology, Warsaw, Poland, in

1984 and 1990. Since fall 2007, he has been with the University of Nebraska-Lincoln as Professor of Computer and Electronics Engineering at the Peter Kiewit Institute, Omaha, NE. The main areas of his research interests include space-time signal processing, diversity combining, indoor propagation of microwaves, as well as protocols for wireless ad hoc networks.

e-mail: twysocki@mail.unomaha.edu

University of Nebraska-Lincoln

Omaha, USA



Beata J. Wysocki received the M.Eng. degree in electrical engineering from the Warsaw University of Technology, Warsaw, Poland, in 1990 and the Ph.D. degree from the Australian Telecommunications Research Institute at Curtin University of Technology, Perth, Australia, in 2000. Her research interests include space-time sig-

nal processing, sequence design for direct sequence (DS) code-division multiple-access (CDMA) data networks, and optimization of ultra-wide-band (UWB) communication systems.

e-mail: beatajoanna33@yahoo.com

University of Nebraska-Lincoln

Omaha, USA