

Analytical Modeling of the WCDMA Interface with Packet Scheduling

Maciej Stasiak, Piotr Zwierzykowski, and Janusz Wiewióra

Abstract— The article presents the application of a new analytical model of the full-availability group carrying a mixture of different multi-rate traffic classes with compression property for modeling the WCDMA radio interface with packet scheduling. The proposed model can be directly used for modeling of the WCDMA interface in the UMTS network servicing different traffic classes. The described model can be applied for a validation of the efficiency of the WCDMA interface measured by the blocking probability and the average carried traffic for particular traffic classes.

Keywords— analytical model, radio interface, UMTS.

1. Introduction

The increase in popularity of data transfer services in mobile networks of the second and the third generations has been followed by an increase in the interest in methods for dimensioning and optimization of networks servicing multi-rate traffic. In traffic theory, the issues on the problem are increasingly becoming part of the mainstream analysis [1]–[11]. This situation is primarily caused by the special conditions in the construction of these networks, and by the construction of the infrastructure of the access radio network in particular – as its development or extension needs a precise definition and assessment of clients' needs and is relatively time-consuming. Cellular network operators define, on the basis of service level agreement (SLA), a set of the key performance indicator (KPI) parameters that serve as determinants in the process of network dimensioning and optimization [12]. Dimensioning can be presented as an unending and on-going process of analyzing and designing of the network. To make this work effective it is thus necessary to work out algorithms that would, in a reliable way, model the parameters of a designed network [13].

One of the mechanisms that should be analyzed in view of performance (expectations) are radio access algorithms. This article discusses and analyzes packet scheduling that is used for transmission of background and interactive traffic (the guaranteed minimum bandwidth is not a requirement), but also for the streaming class, which requires the minimum bandwidth, not being at the same time very sensitive to delays. The conversational traffic class is carried without scheduling on dedicated channels [14].

The paper has been divided into five sections. Section 2 recalls basic model of a full-availability group (FAG) with multi-rate traffic which is used in the model presented in Section 3. Section 3 describes an analytical model of

the full-availability group with traffic compression. Section 4 shows application of the model in the universal mobile telecommunication system (UMTS) network for modeling of the wideband code division multiple access (WCDMA) interface with packet scheduling. This section also includes the results obtained in the study of the system. The final Section 5 sums up the discussion.

2. Model of the FAG

Let us assume that the total capacity of the full-availability group with multi-rate traffic is equal to V basic bandwidth units (BBUs). The group is offered M independent classes of Poisson traffic streams having the intensities: $\lambda_1, \lambda_2, \dots, \lambda_M$. The class i call requires t_i BBUs to set up a connection. The holding time for calls of particular classes has an exponential distribution with the parameters: $\mu_1, \mu_2, \dots, \mu_M$. Thus, the mean traffic offered to the system by the class i traffic stream is equal to:

$$A_i = \lambda_i / \mu_i. \quad (1)$$

The demanded resources in the group for servicing particular classes can be treated as a call demanding an integer number of (BBUs) [15]. The value of BBU, i.e., R_{BBU} , is calculated as the greatest common divisor of all resources demanded by traffic classes offered to the system:

$$R_{BBU} = \text{GCD}(R_1, \dots, R_M), \quad (2)$$

where R_i is the amount of resources demanded by class i call in kbit/s.

The multi-dimensional Markov process in FAG can be approximated by the one-dimensional Markov chain which can be described by Kaufman-Roberts recursion [16], [17]:

$$n [P_n]_V = \sum_{i=1}^M A_i t_i [P_{n-t_i}]_V, \quad (3)$$

where $[P_n]_V$ is the probability of state n BBUs being busy, and t_i is the number of BBUs required by a class i call:

$$t_i = \lfloor R_i / R_{BBU} \rfloor. \quad (4)$$

On the basis of formula (3) the blocking probability E_i for class i stream can be expressed as follows:

$$E_i = \sum_{n=V-t_i+1}^V [P_n]_V, \quad (5)$$

where V is the total capacity of the group and is expressed in BBUs ($V = \lfloor V_{phy} / R_{BBU} \rfloor$, where V_{phy} is the physical capacity of group in kbit/s).

The diagram in Fig. 1 corresponds to formula (3) for the system with two call streams ($M = 2$, $t_1 = 1$, $t_2 = 2$). The $y_i(n)$ symbol denotes the so-called *reverse transition rate* of a class i service stream outgoing from state n . This parameter can be calculated on the basis of the local equations of equilibrium in the Markov chain [16], [18]:

$$y_i(n) = \begin{cases} A_i [P_{n-t_i}]_V / [P_n]_V & \text{for } n \leq V, \\ 0 & \text{for } n > V. \end{cases} \quad (6)$$

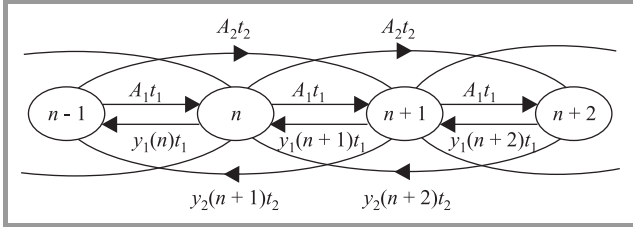

Fig. 1. Fragment of a diagram of the one-dimensional Markov chain in a multi-rate system ($M = 2$, $t_1 = 1$, $t_2 = 2$).

The reverse transition rate determines the average number of class i calls serviced in the state n .

3. The FAG with Compression

The following section recall the basics assumptions of the model of a full-availability group with traffic compression which was firstly described in [11].

Let us assume now that a full-availability group services a mixture of different multi-rate traffic streams with the compression property. This means that in the traffic mixture there are such calls in which a change in demands (requirements) follows evenly as the result of the overload of the system.

In this group it is assumed that the system services simultaneously a mixture of different multi-rate traffic classes, while these classes are divided into two sets: classes whose calls can change requirements (demands) while being serviced and classes that do not change their demands in their service time.

In the considered model the following notation is used:

- \mathbb{M}_k denotes a set of classes with the possibility of compression, while $M_k = |\mathbb{M}_k|$ is the number of compressed traffic classes.
- \mathbb{M}_{nk} is a set of classes without compression, and $M_{nk} = |\mathbb{M}_{nk}|$ denotes the number of classes without compression.

It was assumed in the model that all classes undergoing compression were compressed in the same degree. The measure of a possible change of requirements is *maximum compression coefficient* that determines the ratio of the maximum demands to minimum demands for a given

traffic classes. The coefficient K_{\max} can be determined on the basis of the dependence:

$$\forall_{j \in \mathbb{M}_k} K_{\max} = \frac{t_{j,\max}}{t_{j,\min}}, \quad (7)$$

where $t_{j,\max}$ and $t_{j,\min}$ denote, respectively, the maximum and the minimum number of basic bandwidth units demanded by a call of class j .

We assume that the system will be treated as a full-availability group with multi-rate traffic. The occupancy distribution in such a system can be expressed by the recursive Kaufman-Roberts formula (3), under the assumption that the amount of required resources by calls of the classes with compression property is minimum. In the case of a system carrying a mixture of traffic streams that undergo and do not undergo compression, the occupancy distribution (3) will be more conveniently expressed by dividing the two types of traffic¹:

$$n [P_n]_V = \sum_{i=1}^{M_{nk}} A_i t_i [P_{n-t_i}]_V + \sum_{j=1}^{M_k} A_j t_{j,\min} [P_{n-t_{j,\min}}]_V, \quad (8)$$

where $t_{j,\min}$ is the minimum number of demanded BBUs in a given occupation state of the system by a call of class j that belongs to the set \mathbb{M}_k .

The blocking (loss) coefficient in the full-availability group will be determined by the dependence (6) that, in the considered case, will take on the following form:

$$E_i = B_i = \begin{cases} \sum_{n=V-t_i+1}^V [P_n]_V & \text{for } i \in \mathbb{M}_{nk}, \\ \sum_{n=V-t_{i,\min}+1}^V [P_n]_V & \text{for } i \in \mathbb{M}_k. \end{cases} \quad (9)$$

In equations (8) and (9), the model is characterized by the parameter $t_{i,\min}$ which is the minimum number of BBUs demanded by a call of class i under the conditions of maximum compression. Such an approach is indispensable to determine the blocking probabilities in the system with compression, since blocking states will occur in the conditions of maximum compression. The maximum compression determines such occupancy states of the system in which further decrease in the demands of calls of class i is not possible.

In order to determine a possibility of the compression of the system it is necessary to evaluate the number and the kind of calls serviced in a given occupancy state of the system. For this purpose we can use formula (5) that makes it possible to determine the average number of calls of class i serviced in the occupancy state n BBUs. This dependence,

¹Further on in the paper, the terms “a set of classes with the possibility of compression” and “class with the possibility of compression”, will be simplified to a “a set of classes with compression” and, respectively, a “class with compression”.

under the assumption of the maximum compression, can be written in the following way:

$$y_i(n) = \begin{cases} \frac{A_i [P_{n-t_i}]_V}{[P_n]_V} & \text{for } i \in \mathbb{M}_{nk}, \\ \frac{A_i [P_{n-t_{j,\min}}]_V}{[P_n]_V} & \text{for } i \in \mathbb{M}_k. \end{cases} \quad (10)$$

On the basis of formula (10), knowing the demands of individual calls, we can thus determine the total average carried traffic in state n , under the assumption of the maximum compression:

$$\begin{aligned} Y_{\max}(n) &= Y^{nk}(n) + Y_{\max}^k(n) \\ &= \sum_{i=1}^{M_{nk}} y_i(n) t_i + \sum_{j=1}^{M_k} y_j(n) t_{j,\min}, \end{aligned} \quad (11)$$

where $Y_{\max}^k(n)$ is the average number of busy BBUs in state n occupied by calls that undergo compression, whereas $Y^{nk}(n)$ is the average number of busy BBUs in state n occupied by calls without compression.

Let us assume that the value of the parameter $Y^{nk}(n)$ refers to non-compressed traffic and is independent of the compression of the remaining calls. The real values of the carried traffic, corresponding to state n (determined in the condition of maximum compression), will depend on the number of free BBUs in the system. We assume that the real system operates in such a way as to guarantee the maximum use of the resources, i.e., a call of a compressed class always tends to occupy free resources and decreases its maximum demands in a least possible way. Thus, the real traffic value $Y(n)$, carried in a system in a given state corresponding to state n (determined in maximum compression) can be expressed in the following way²:

$$Y(n) = Y^{nk}(n) + Y^k(n) = \sum_{i=1}^{M_{nk}} y_i(n) t_i + \sum_{j=1}^{M_k} y_j(n) t_j(n). \quad (12)$$

The parameter $t_j(n)$ in formula (12) determines the real value of a demand of class j in state n :

$$\forall_{j \in \mathbb{M}_k} t_{j,\min} < t_j(n) \leq t_{j,\max}. \quad (13)$$

The measure of the degree of compression in state n is the compression coefficient $\xi_k(n)$, which can be expressed in the following way:

$$t_j(n) = t_{j,\min} \xi_k(n). \quad (14)$$

Taking into consideration (14), the average number of busy BBUs occupied by calls with compression can be written thus:

$$Y^k(n) = \sum_{j=1}^{M_k} y_j(n) t_j(n) = \xi_k(n) \sum_{j=1}^{M_k} y_j(n) t_{j,\min}. \quad (15)$$

²Further on in the description, to simplify the description, we will use the term "in state n " instead of the description "a given state n in maximum compression".

We assume in the considered model that the system operates in such a way that guarantees the maximum use of available resources and this means that calls that undergo compression will always tend to occupy free resources, decreasing their demands in the least possible way. The other param-

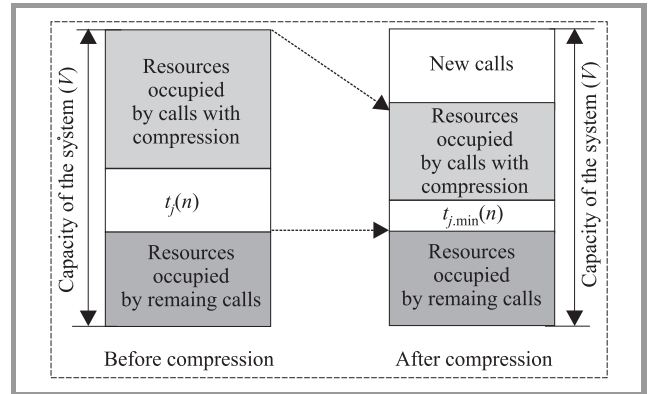

Fig. 2. Exemplary system with compression.

eter of the considered system, beside the blocking (loss) probability, is the average number of busy BBUs in the system occupied by calls with compression (formula (15)). In order to determine this parameter, the knowledge of the compression coefficient $\xi_k(n)$ is indispensable. This coefficient can also be defined as the ratio of potentially available resources for the service of calls with compression to the resources occupied by these calls in the state of maximum compression. Thus, we can write (Fig. 2):

$$\xi_k(n) = \frac{V - Y^{nk}(n)}{Y_{\max}^k(n)} = \frac{V - Y^{nk}(n)}{n - Y^{nk}(n)}. \quad (16)$$

The numerator in formula (16) expresses the total amount of resources of the system which can be occupied by calls of the class with compression, whereas the denominator can be interpreted as the amount of resources which can be occupied by the calls of the class with compression, under the assumption that the system (FAG) is in the state n BBUs being busy. A constraint to the value of the coefficient (16) is the maximum compression coefficient determined on the basis of the dependence (7). This constraint can be taken into account by defining formally the compression coefficient in the following way:

$$\xi_k(n) = \begin{cases} K_{\max} & \text{for } \xi_k(n) \geq K_{\max}, \\ \xi_k(n) & \text{for } 1 \leq \xi_k(n) < K_{\max}. \end{cases} \quad (17)$$

The compression coefficient determined by formula (17) is not dependent on the traffic class. This results from the adopted assumption in the model of the same degree of compression for all traffic classes that undergo the mechanism of compression.

Knowing the value of the compression coefficient in every state n , we can determine the average resources occupied by calls of class j with compression:

$$Y_j^k = \sum_{n=0}^V y_j(n) [\xi_k(n) t_{j,\min}] [P_n]_V. \quad (18)$$

On the basis of the average resources occupied by calls of class j , we can determine the average resources occupied by calls of all traffic classes with compression:

$$Y^k = \sum_{j=0}^{M_k} Y_j^k. \tag{19}$$

Let us note that the value Y^k in formula (19) is the average carried traffic in the system by calls which undergo compression.

4. Application of the Model

4.1. UMTS Architecture

Let us consider the structure of the UMTS network illustrated in Fig. 3. The presented network consists of three functional blocks designated, respectively: UE (user equipment), UTRAN (UMTS terrestrial radio access network) and CN (core network). The following notation has been adopted in Fig. 3: RNC is the radio network controller, WCDMA is a radio interface and Iub is the interface connecting node B and RNC. In the dimensioning process

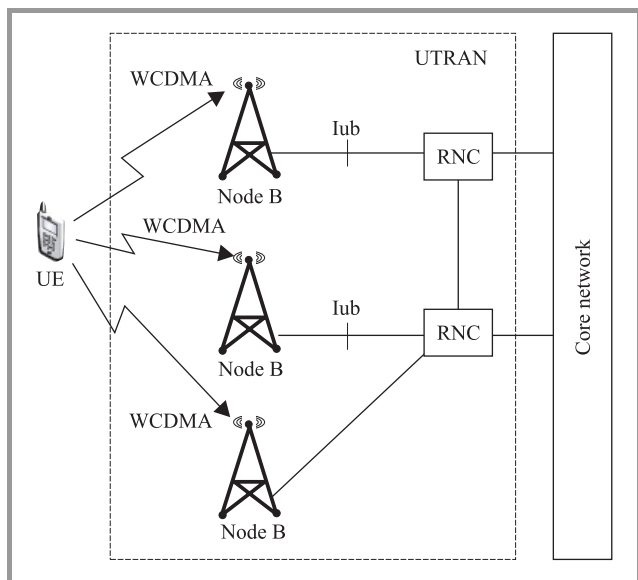

Fig. 3. Elements of the UMTS network structure.

for the UMTS network, an appropriate dimensioning of the connections in the access part (UTRAN), i.e., the radio interface between the user and node B, and the Iub connections between node B and the radio network controller, has a particular significance. The issues pertaining to Iub interface dimensioning are already discussed in the subject literature, for example in the earlier work of the present authors, e.g., [19], also models dedicated for radio interface dimensioning are widely discussed in the subject literature, for example in earlier works of the present authors, e.g., [11], [20]–[23], whereas those dealing with dimensioning of the WCDMA interface with the packet scheduling functionality have not been hitherto addressed in a satisfactory way.

4.2. Packet Scheduling

Packet scheduling is an important mechanism that should be included in the analysis of the efficiency of the WCDMA radio interface in the UMTS networks. In the relevant literature we can consider user-specific and cell-specific packet scheduling algorithms [14].

In user-specific packet scheduling, scheduler controls the use of transport channels and their bit rate depending on the volume of traffic, informing of a demand for packet bearers with appropriate bit rates.

Cell-specific scheduler is responsible for appropriate distribution of the capacity of the base station between users of non-real time services (i.e., background, interactive and streaming). Bit rates assigned to users are controlled every 100 ms – 1 s and if the load approaches the target load level, the scheduler can reduce the load by decreasing bit rates of the packet bearer. The change in the capacity for scheduled connections in relation to the resources assigned for non-scheduled connections is presented in Fig. 4.

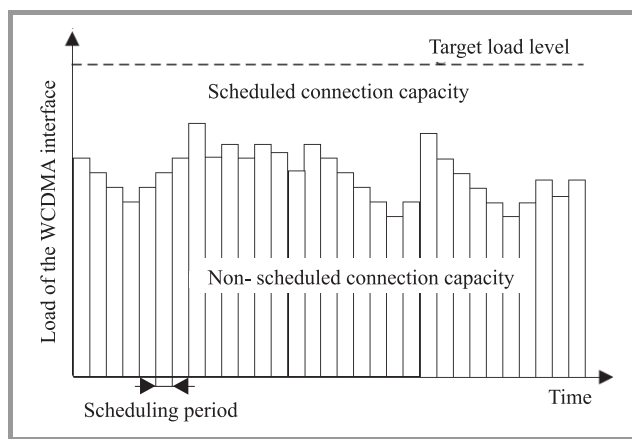

Fig. 4. Illustration of cell-specific packet scheduler.

An example of the operation of the algorithm is presented in Fig. 5, where the calls of non-real time connections (based on the user-specific scheduler) are admitted until target load level is reached and then, in the case of a con-

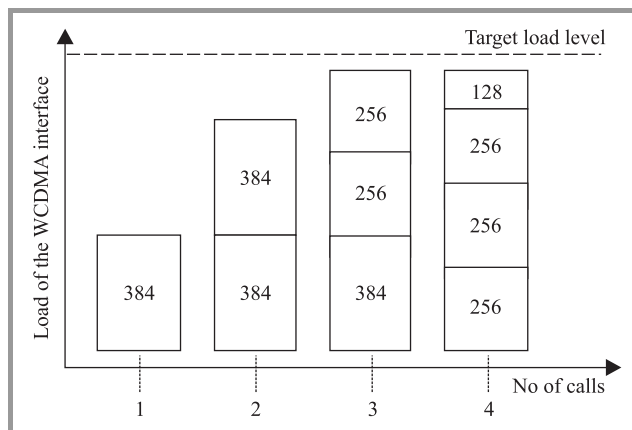

Fig. 5. An example of operation of the packet scheduler.

tinuing arrival process of new calls, connections are compressed.

Figure 5 shows relation between the load of the interface and the number of serviced calls. In Fig. 5 the first arriving call required 384 kbit/s and it was admitted for service, the second arriving call which required 384 kbit/s was also admitted for service. When the third call arrived it also required 384 kbit/s and was not admitted, but the compression mechanism of one of already admitted calls to 256 kbit/s was applied and the call is assigned the resources of 256 kbit/s. The last fourth arriving call required 384 kbit/s and it was not admitted, but the re-configuration of the resources ensues (as it is presented in the figure).

With compression mechanisms, one of the ways of the bit rate analysis is to base the evaluation on the average bit rate. The WCDMA interface with packet scheduling can be treated as the full-availability group with multi-rate traffic and compression property (Section 3).

4.3. Calculation Algorithm

On the basis of the considerations presented in Sections 2 and 3, the algorithm of blocking probability E_i and average occupied traffic Y_i^k calculations for the WCDMA interface may be written in the form of Algorithm 1.

Algorithm 1: Algorithm of blocking probabilities calculation in the downlink direction

1. Calculation of offered traffic load A_i of class i Eq. (1).
 2. Designation of the value of t_{BBU} as the greatest common divisor Eq. (2).
 3. Determination of the value of t_i as the integer number of demanded resources by class i calls Eq. (4).
 4. Calculation of state probabilities $[P_n]_V$ in FAG Eq. (8).
 5. Designation of the blocking probability of class i Eq. (9).
 6. Determination of the reverse transition rate for class i Eq. (10).
 7. Calculation of the average compression coefficient Eq. (17).
 8. Determination of the average traffic of class i carried by WCDMA Eq. (18).
-

4.4. Numerical Study

The proposed analytical model of the WCDMA interface is an approximate one. Thus, the results of the analytical calculations of the WCDMA interface were compared with the results of the simulation experiments. The study was

carried out for users demanding a set of following services in the downlink direction:

- Class 1: speech – $t_{1,\min} = 12 \text{ kbit/s} = 12 \text{ BBUs}$.
- Class 2: video – $t_{2,\min} = 64 \text{ kbit/s} = 64 \text{ BBUs}$.
- Class 3: data 384/384 – $t_{3,\min} = 128 \text{ kbit/s} = 128 \text{ BBUs}$ (non-real time service).

In the presented study, it was assumed that:

- The hard capacity of the WCDMA interface in the downlink direction [13], [23].
- R_{BBU} was equal to 1 kbit/s.
- The coefficient K_{\max} was equal to 3.
- The capacity of the WCDMA interface was limited to 80% of the physical capacity: $V_{DL} = 1600 \text{ kbit/s} = 1600 \text{ BBUs}$.
- The services were offered in the following proportions:

$$A_1 t_1 : A_2 t_2 : A_3 t_3 = 15 : 5 : 40.$$

It was assumed that the main part of traffic is generated by data service followed by speech service, while the smallest part of traffic comes from video service.

Figure 6 shows the dependency of the blocking probability in relation to traffic offered per BBU in the WCDMA interface. The presented results were obtained for the minimum value of required (demanded) resources for traffic classes with the compression property.

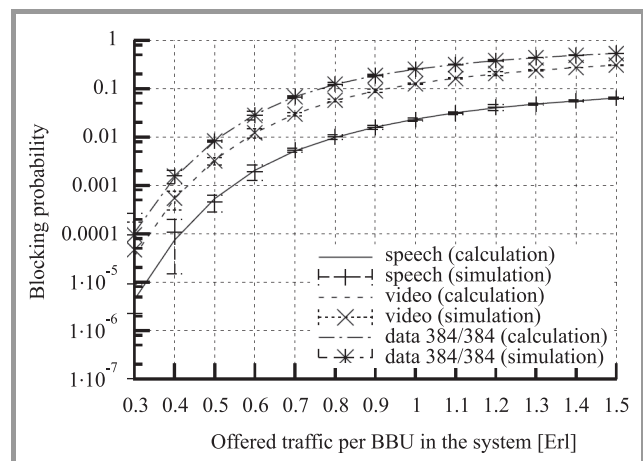

Fig. 6. Blocking probabilities for all traffic classes carried by the WCDMA interface.

Figures 8 and 7 present the influence of traffic offered per BBU in the WCDMA interface on the average carried traffic by WCDMA (Fig. 7), and on the value of the comp-

ression coefficient (Fig. 8). It can be noticed that the exponential dependence characterizes the plots corresponding to the traffic class with compression in both figures. The linear relation between compression coefficient and the average carried traffic (see Eq. (18)) explains the similar character of the curves in the both figures. The results con-

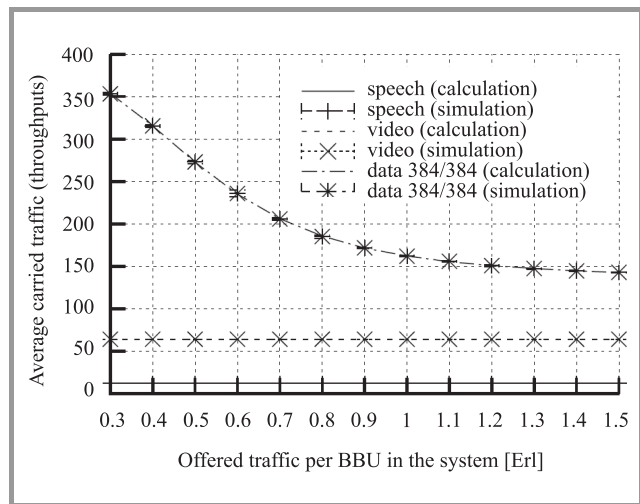

Fig. 7. Average carried traffic for particular classes serviced by the WCDMA interface.

firm strong dependence between the average carried traffic (throughput) and the load of the system – the more overloaded system the lower value of throughput. The character of the curves results from the decrease of the amount of resources required by a call of class with compression: the more overloaded system the smaller demands of the calls with compression.

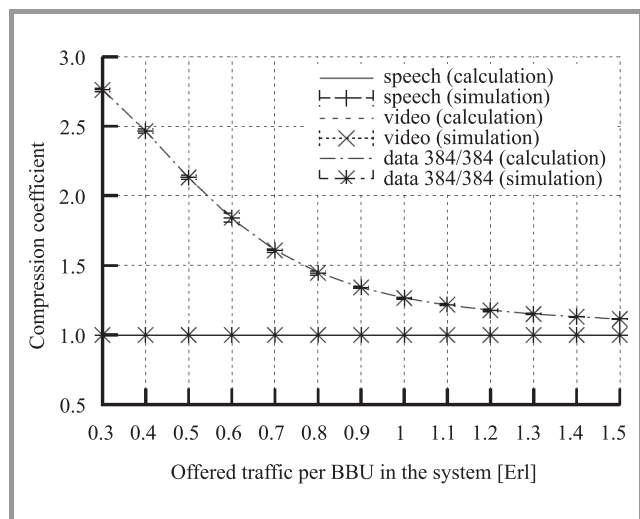

Fig. 8. Compression coefficient in relation to traffic offered to the WCDMA interface.

The results of the simulations are shown in the charts in the form of marks with 95% confidence intervals calculated

after the *t*-student distribution. 95% confidence intervals of the simulation are almost included within the marks plotted in the figures.

5. Conclusions

This paper proposes a new analytical model with compression that finds its application in modeling the WCDMA interface with packet scheduler, in the UMTS network, carrying a mixture of different multi-rate traffic classes.

The presented analytical method allows to determine the blocking probability for all traffic classes serviced by the WCDMA interface. It should be noted that in the model we assume the “worst case” approach in the WCDMA modeling and dimensioning that makes our calculations independent of the way of operation of the scheduler [24], which underlines the universal character of the method.

It is worth emphasizing that the described analytical model could be used for a determination of the average carried traffic for particular traffic classes serviced by the WCDMA interface.

The KPI, being an indispensable element of SLA, can be defined differently depending on the kind of the receiver of information. Thus, KPI will be defined differently for engineering staff and differently for non-technical staff often involved in decision making concerning expenditures that are to ensure appropriate quality of services. While such parameter as the blocking probability is well understood by engineers, clients and non-technical staff may have some problems with the interpretation of the indicator and this group of users will rather prefer the average value as being more intuitive.

The average value of carried traffic is also very characteristic for some services such as data (e.g., file transfer protocol – FTP). With regards to the above factors, a necessity appears of a skilful use of the average value of carried traffic as the initial value in the process of designing and dimensioning of the UMTS networks without violating the basic merits of the adopted model that are necessary for a system to operate successfully. Thus, this parameter is an important factor in 3G network capacity calculations, i.e., in dimensioning and optimization of WCDMA and Iub interfaces.

References

- [1] D. Staehle and A. Mäder, “An analytic approximation of the uplink capacity in a UMTS network with heterogeneous traffic”, in *18th Int. Telegraf. Congr. ITC 18*, Berlin, Germany, 2003, pp. 81–91.
- [2] V. B. Iversen and E. Epifania, “Teletraffic engineering of multi-band W-CDMA systems”, in *Network Control and Engineering for Qos, Security and Mobility II*. Norwell: Kluwer, 2003, pp. 90–103.
- [3] V. B. Iversen, V. Benetis, and H. N. Trung, “Evaluation of multi-service CDMA networks with soft blocking”, in *ITC 16th Spec. Sem. Perfor. Eval. Mob. Wirel. Syst.*, Antwerp, Belgium, 2004, pp. 212–216.

- [4] D. Staehle, "Analytic methods for UMTS radio network planning". Ph.D. thesis, Bayerische Julius-Maximilians-Universitat Wurzburg, 2004.
- [5] K. Subramaniam and A. A. Nilsson, "Tier-based analytical model for adaptive call admission control scheme in a UMTS-WCDMA system", in *Proc. Veh. Technol. Conf.*, Stockholm, Sweden, 2005, vol. 4, pp. 2181–2185.
- [6] K. Subramaniam and A. A. Nilsson, "An analytical model for adaptive call admission control scheme in a heterogeneous UMTS-WCDMA system", in *Proc. Int. Conf. Commun.*, Seoul, Korea, 2005, vol. 5, pp. 3334–3338.
- [7] I. Koo and K. Kim, *CDMA Systems Capacity Engineering. Mobile Communications*. Boston, London: Artech House, 2005.
- [8] I. Koo and K. Kim, "Erlang capacity of multi-service multi-access systems with a limited number of channel elements according to separate and common operations", *IEICE Trans. Commun.*, vol. E89-B, no. 11, pp. 3065–3074, 2006.
- [9] G. A. Kallos, V. G. Vassilakis, and M. D. Logothetis, "Call blocking probabilities in a W-CDMA cell with fixed number of channels and finite number of traffic sources", in *Proc. 6th Int. Conf. Commun. Syst., Netw. Dig. Sig. Proces.*, Graz, Austria, 2008 pp. 200–203.
- [10] V. G. Vassilakis and M. D. Logothetis, "The wireless Engset multi-rate loss model for the handoff traffic analysis in W-CDMA networks", in *Proc. 19th Int. Symp. Pers., Indoor Mob. Radio Commun.*, Cannes, France, 2008, pp. 1–6.
- [11] M. Stasiak, P. Zwierzykowski, J. Wiewióra, and D. Parniewicz, "An approximate model of the WCDMA interface servicing a mixture of multi-rate traffic streams with priorities", in *Computer Performance Engineering*, Lecture Notes in Computer Science, vol. 5261. Berlin: Springer, 2008, pp. 168–180.
- [12] J. Laiho, A. Wacker, and T. Novosad, *Radio Network Planning and Optimization for UMTS*. 2 ed. Chichester: Wiley, 2006.
- [13] M. Stasiak, P. Zwierzykowski, and M. Głąbowski, *Modelowanie i wymiarowanie ruchomych sieci bezprzewodowych*. Warsaw: Wydawnictwa Komunikacji i Łączności, 2009 (in Polish).
- [14] H. Holma and A. Toskala, *WCDMA for UMTS. Radio Access for Third Generation Mobile Communications*. Chichester: Wiley, 2000.
- [15] *Broadband Network Teletraffic, Final Report of Action COST 242*, J. W. Roberts, V. Mocchi, and I. Virtamo, Eds. Commission of the European Communities. Berlin: Springer, 1996.
- [16] J. S. Kaufman, "Blocking in a shared resource environment", *IEEE Trans. Commun.*, vol. 29, no. 10, pp. 1474–1481, 1981.
- [17] J. W. Roberts, "A service system with heterogeneous user requirements – application to multi-service telecommunications systems", in *Proceedings of Performance of Data Communications Systems and Their Applications*, G. Pujolle, Ed. Amsterdam: North Holland, 1981, pp. 423–431.
- [18] M. Głąbowski, "Modelling of state-dependent multi-rate systems carrying BPP traffic", *Ann. Telecommun.*, vol. 63, no. 7–8, pp. 393–407, 2008.
- [19] M. Stasiak, J. Wiewióra, and P. Zwierzykowski, "Analytical modelling of the Iub interface in the UMTS network", in *Proc. 6th Int. Conf. Commun. Syst., Netw. Dig. Sig. Proces.*, Graz, Austria, 2008.
- [20] M. Stasiak, A. Wiśniewski, and P. Zwierzykowski, "Blocking probability calculation in the uplink direction for cellular systems with WCDMA radio interface", in *Proc. 3rd Polish-German Teletraf. Symp.*, P. Buchholtz, R. Lehnert, and M. Pióro, Eds., Dresden, Germany, 2004, pp. 65–74.
- [21] M. Głąbowski, M. Stasiak, A. Wiśniewski, and P. Zwierzykowski, "Uplink blocking probability calculation for cellular systems with WCDMA radio interface, finite source population and differently loaded neighbouring cells", in *Proc. Asia-Pacific Conf. Commun.*, Perth, Australia, 2005.
- [22] M. Głąbowski, M. Stasiak, A. Wiśniewski, and P. Zwierzykowski, "Uplink blocking probability calculation for cellular systems with WCDMA radio interface and finite source population", in *Performance Modelling and Analysis of Heterogeneous Networks*. Wharton: River Publ., 2009, pp. 301–318.
- [23] M. Stasiak, A. Wiśniewski, P. Zwierzykowski, and M. Głąbowski, "Blocking probability calculation for cellular systems with WCDMA radio interface servicing PCT1 and PCT2 multirate traffic", *IEICE Trans. Commun.*, vol. E92-B, no. 4, pp. 1156–1165, 2009.
- [24] H. Holma and A. Toskala, *HSDPA/HSUPA for UMTS: High Speed Radio Access for Mobile Communications*. Chichester: Wiley, 2006.



Maciej Stasiak is a Professor at the Poznań University of Technology, Poland. He received the M.Sc. and Ph.D. degrees in electrical engineering from the Institute of Communications Engineering, Moscow, Russia, in 1979 and 1984, respectively. In 1996 he received D.Sc. degree from the Poznań University of Technology in electrical engineering. In 2006 he was nominated as Full Professor. Between 1983–1992 he worked in Polish industry as a designer of electronic and microprocessor systems. In 1992, he joined the Institute of Electronics and Telecommunications, Poznań University of Technology, where he is currently a Head of the Chair of Communications and Computer Networks at the Faculty of Electronics and Telecommunications at the Poznań University of Technology. He is the author or co-author of more than 200 scientific papers and three books. He is engaged in research and teaching in the area of performance analysis and modeling of multiservice networks and switching systems.

e-mail: stasiak@et.put.poznan.pl
 Chair of Communications and Computer Networks
 Poznań University of Technology
 Polanka st 3/228
 60-965 Poznań, Poland



Piotr Zwierzykowski received the M.Sc. and Ph.D. degrees in telecommunication from the Poznań University of Technology, Poland, in 1995 and 2002, respectively. Since 1995 he has been working in the Faculty of Electronics and Telecommunications, Poznań University of Technology. He is currently an Assistant Professor in the Chair of Communications and Computer Networks. He is the author or co-author over 120 papers. He is engaged in research and teaching in the area of performance analysis and modeling of multiservice switching systems.

e-mail: pzwierz@et.put.poznan.pl
 Chair of Communications and Computer Networks
 Poznań University of Technology
 Polanka st 3/231
 60-965 Poznań, Poland



Janusz Wiewióra received the M.Sc. degree in telecommunication from Warsaw University of Technology, Poland, in 2000. Between 1998–2000 he worked as an expert responsible for international frequency coordination for digital radio (DAB), medium wave band radio and long wave band radio in National Radiocommunication

Agency. He is an expert leading the BSS Optimization Section at the Polska Telefonia Cyfrowa sp. z o.o. (PTC)

responsible for dimensioning and optimization the dual band 900/1800 GSM network and UMTS network. During his work at PTC he has kept in touch with Poznań University of Technology, where he was engaged in research in the area of performance analysis and modeling of multi-rate mobile networks. Until now he has published over 10 papers.

e-mail: jwiewiora@era.pl

BSS Optimization Section

Polska Telefonia Cyfrowa Sp. z o.o.

Regional Office Warsaw

Annopol st 3

03-236 Warsaw, Poland