

Optimum receiver performance of TH-PPM ultra wideband system in multiple user interference

Mohammad Upal Mahfuz, Kazi M. Ahmed, and Nandana Rajatheva

Abstract—This paper demonstrates optimum receiver performance in terms of bit error rate (BER) for time hopping pulse position modulation (TH-PPM) ultra wideband (UWB) system in multiple user interference environment for indoor radio communication. Equal gain combining and selective gain combining have been demonstrated in terms of ideal RAKE (ARAKE), selective RAKE (SRAKE) and partial RAKE (PRAKE) receiver performances. The recently accepted IEEE 802.15.3a model of the UWB channel has been used to describe UWB propagation in indoor environment. Two channel scenarios named CM-1 and CM-3 for IEEE 802.15.3a channel model have been investigated principally. Finally, this paper concludes with an approximation of equivalence of number of fingers in SRAKE and PRAKE receivers as well as an indication of SNR gains achievable as the RAKE finger number is increased, especially with multiple user interference (MUI), for a 16.6 Mbit/s UWB system.

Keywords— optimum receiver performance, TH-PPM, ultra wideband, multiple user interference.

1. Introduction

Ultra wideband impulse radio (UWB-IR) is currently receiving a great deal of global attention because of its ability to provide higher data rate with low cost and relatively low power consumption. Impulse radio UWB communicates with baseband pulses of very short duration on the order of tenth of a nanosecond. According to the regulation of Federal Commission of Communications (FCC), a signal is defined as UWB signal if it has a -10 dB fractional bandwidth, F_{BW} greater than (or equal to) 0.20 or it occupies at least 500 MHz of the spectrum [1], the fractional bandwidth being expressed as

$$F_{BW} = 2 \frac{f_H - f_L}{f_H + f_L} \geq 0.20, \quad (1)$$

where f_H and f_L correspond to the -10 dB upper and lower frequencies, respectively. The FCC has also regulated the spectral shape and maximum power spectral density (-41.3 dBm/MHz) of the UWB radiation in order to limit the interference with other communication systems like UMTS or WLAN [2]. The waveforms that are used for UWB radio are very short in duration, causing their energy to be spread across the frequency spectrum.

With UWB signals the dense multipath can be resolved, allowing a RAKE receiver for signal demodulation. Multiple access in UWB communications is accomplished with traditional spread-spectrum techniques. Most of the research conducted so far is concerned with time hopping (TH) spread spectrum, associated with either binary pulse position modulation (TH-PPM) [3] or bipolar pulse amplitude modulation (TH-PAM) [4]. The performance of RAKE receivers operating with TH-PPM has been investigated in [5] in the absence of multiple user interference (MUI) and assuming perfect channel knowledge. The impact of MUI on the detection process is discussed in [3] with line-of-sight (LOS) propagation. Unfortunately, in the presence of MUI the question of optimum performance is so complex that physical intuition does not help and an analytical approach seems impossible [4]. Clearly, MUI plays a role both in channel estimation as well as in receiver performance.

In this paper we extend these results in various ways. We have compared the performances ideal, selective and partial RAKE receiver performances for TH-PPM UWB scheme in presence of low to moderate multiple user interference using two channel models named CM-1 and CM-2 as described recently by the IEEE 802.15.3a [6] standardization group for use in indoor UWB communications [7]. We have also shown how the system performance changes as the number of RAKE fingers varies. In particular, our research targets optimum receiver performance and comparison of the system performances between CM-1 and CM-3, which are 0–2 m LOS and 4–10 m NLOS channel conditions and are used very often in UWB system performance evaluation studies. Finally, since indoor radio communication is affected by a large number of multipaths, the equivalence between selective RAKE (SRAKE) and partial RAKE (PRAKE) finger numbers is another important aspect that this paper has addressed regarding TH-PPM UWB scheme. The paper is organized as follows: Section 2 provides with a brief description of the concept of multiuser interference. The discussion is followed by Section 3 describing the complete system model under investigation as well as detailed simulation environment. Section 4 briefly describes RAKE receiver principle regarding SRAKE and PRAKE operations, which is then followed by Section 5 discussing the results obtained with extensive simulation of the TH-PPM UWB system. Finally, Section 6 concludes the paper.

2. Concept of multiuser interference

Multiple user interference is modeled as signals coming from other UWB users having the same basic signal characteristics as those of the user of interest, but using different spreading codes. Assuming a total of N_u users, the received signal $r(t)$ can be written as

$$r(t) = s^{(1)}(t) \otimes h^{(1)}(t) + i(t) + n(t), \quad (2)$$

where $s^{(1)}(t)$ is the signal of interest at the output of the transmitting antenna, $h^{(1)}(t)$ represents the impulse response of the channel corresponding to the user of interest, $n(t)$ is the Gaussian noise and $i(t)$ is the interference coming from the other $(N_u - 1)$ users. Here the interference, $i(t)$ can be defined as

$$i(t) = \sum_{n=2}^{N_u} s^{(n)}(t - \tau_n) \otimes h^{(n)}(t), \quad (3)$$

where $h^{(n)}(t)$ for $n = 2, 3, \dots, N_u$ are the impulse responses of the channels corresponding to the $(N_u - 1)$ interfering users and τ_n is the delay of the arrival time of the n th user from the user of interest, i.e., $s^{(1)}(t)$ for which $\tau_1 = 0$. Each user experiences the channel with a different channel realization so that the channel impulse response

$$h^{(n)}(t) \neq h^{(m)}(t),$$

where $n, m = 1, 2, \dots, N_u, n \neq m$.

Each MUI user has the same power as the user of interest. Interfering users are considered either synchronous or asynchronous with the user of interest. The ‘‘synchronous’’ condition refers to ‘‘frame synchronization’’ where the receiver is synchronized with all other users and can receive all users’ data at the same time instant. On the other hand, in the asynchronous case, the interfering signals arrive at the receiver with resolution of a time sample. The asynchronism is performed between every interfering user and the user of interest, and also among the interfering users.

3. System model

In this paper, TH-PPM transmission has been used in the transmitter section. Time hopping is a widely used multiple access method for UWB radio communications. The most recent IEEE 802.15.3a UWB channel model has been chosen as the channel used for UWB propagation. Details of simulation parameters have been shown in Table 1.

3.1. The UWB pulse shape and modulation schemes

A typical energy normalized UWB TH-PPM signal can be modeled as follows:

$$s_{tr}^{(k)}(t^{(k)}) = \sum_{j=-\infty}^{\infty} w_{tr}(t^{(k)} - jT_f - c_j^{(k)}T_c - d_j^{(k)}\Delta), \quad (4)$$

where c_j is the distinct time hopping sequence, t is the transmitter clock time, w_{tr} is the transmitted monocycle

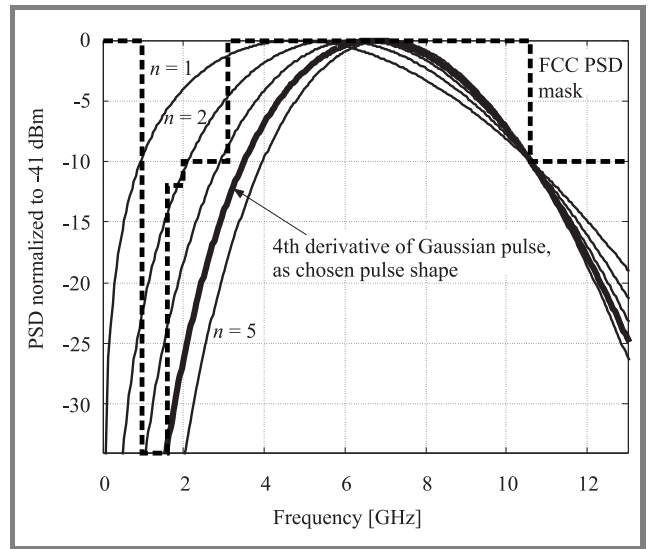

Fig. 1. PSD of 4th order derivative of Gaussian pulse fulfilling indoor UWB PSD requirement for indoor systems.

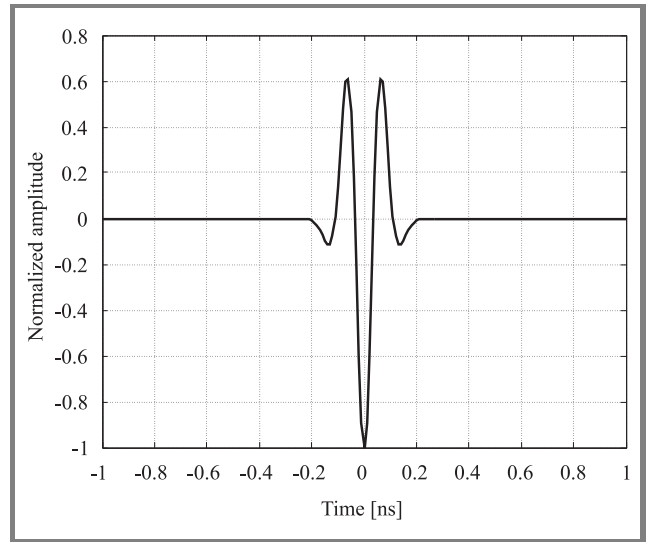

Fig. 2. Fourth order derivative of Gaussian pulse.

waveform, T_f is the pulse repetition time, T_c is the chip duration and d_j are the information symbols and Δ is the PPM pulse shift [3]. In this paper, a pulse position is shifted by 0.5 ns for a data bit 1 under PPM modulation scheme. The fourth derivative of Gaussian pulse that fits the FCC mask in a better manner can be chosen. Based on normalized power spectral density (PSD) of n th order Gaussian derivative pulse, applying bisection method as in [8], the fourth order derivative of Gaussian pulse with pulse shaping factor of 0.168 ns has been chosen in our simulations. The selection of appropriate pulse shape has been shown in Figs. 1 and 2.

3.2. IEEE 802.15.3a UWB channel model

In IEEE 802.15.3a UWB channel model (Fig. 3), a modified Saleh-Valenzuela (S-V) model has been proposed on

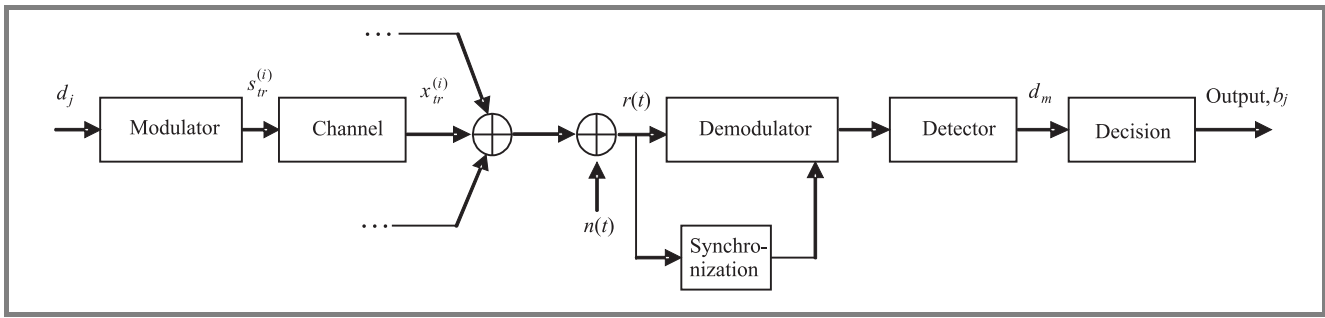

Fig. 3. The system model.

Table 1
Parameters used in simulation of the complete system

Parameters	Values used in simulation
Source data rate [Mbit/s]	16.6
Processing gain [dB]	20.79
Average transmitter power [dBm]	-30
Sampling frequency [GHz]	30
No. of pulse per bit	1
Frame time [ns]	60.1
Periodicity of the TH code	2000
Chip time [ns]	1
Multisuser interference	Single user and multiple user scenarios
Receiver	ARAKE SRAKE, PRAKE with 2, 4, 6, 8, 10, 12, 14, 16, 18, 20, 32 fingers
Channel model	IEEE 802.15.3a, CM-1: 0–2 m, LOS and CM-3: 4–10 m, NLOS
Modulation scheme	PPM
Multiple access	TH
Time shift for PPM [ns]	0.5
Pulse shape	Gaussian 4th derivative
Pulse width [ns]	0.5
Pulse decay factor [ns]	0.168
Code cardinality	5

time (T_l^i), $\{X_i\}$ represents the lognormal shadowing and i refers to the i th realization. So, according to the model, T_l represents the arrival time of the first path (ray) of the l th cluster; $\tau_{k,l}$ is the delay of the k th path (ray) within the l th cluster relative to the first path arrival time, T_l .

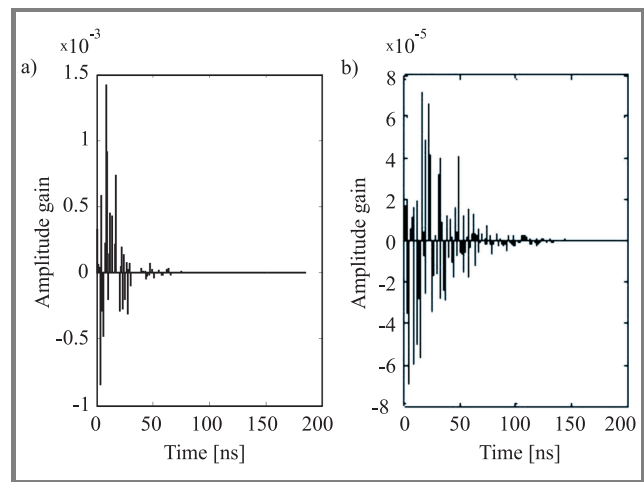

Fig. 4. Discrete time channel impulse response for: (a) CM-1: 0–2 m (LOS); (b) CM-3: 4–10 m (NLOS).

The IEEE 802.15.3a channel model has been explained for four special cases depending on transmitter to receiver distance and the availability of line of sight path be-

Table 2
Model parameters in IEEE 802.15.3a UWB channel [7]

Model parameters	CM-1 LOS at 0–2 m	CM-3 NLOS at 4–10 m
Cluster arrival rate, Λ [1/ns]	0.0233	0.0667
Ray arrival rate, λ [1/ns]	2.5	2.1
Cluster decay factor, Γ	7.1	14
Ray decay factor, γ	4.3	7.9
Std. dev. of cluster log-normal fading, σ_1 [dB]	3.3941	3.3941
Std. dev. of ray log-normal fading, σ_2 [dB]	3.3941	3.3941
Std. dev. of total multipath log-normal fading, σ_x [dB]	3	3

the basis of observed clustering phenomenon in several channel measurements [7]. Lognormal distribution rather than Rayleigh distribution for the multipath gain magnitude has been recommended. In addition, independent fading is assumed for each cluster as well as each ray within the cluster. Therefore, the discrete impulse response of the multipath channel model (Fig. 4) can be described as [6]

$$h_i(t) = X_i \sum_{l=0}^L \sum_{k=0}^K \alpha_{k,l}^i \delta(t - T_l^i - \tau_{k,l}^i), \quad (5)$$

where $\{\alpha_{k,l}^i\}$ are the multipath gain coefficients, $\{T_l^i\}$ is the delay of the l th cluster, $\{\tau_{k,l}^i\}$ is the delay of the k th multipath component relative to the l th cluster arrival

tween them. In this study, CM-1 (0–2 m, LOS) and CM-3 (4–10 m, NLOS) condition of the channel have been used and the corresponding channel parameters are shown in Table 2.

3.3. Receiver section

In the receiver section, selective RAKE receiver has been used. The received signal is the sum of replicas of the transmitted signals. The received signal is, therefore, expressed as

$$r(t) = X \sum_{l=1}^L \sum_{k=1}^K \alpha_{k,l} s_{lr}(t - T_l - \tau_{k,l}) + n(t) + i(t), \quad (6)$$

where $s_{lr}(t)$ is the transmitted signal which suffers from attenuation and time delay in multipath propagation, $n(t)$ is zero mean additive white Gaussian noise (AWGN) and $i(t)$ is the multiple user interference signal. For simulation of this study RAKE receivers with 2, 4, 6, 8, 10, 12, 14, 16, 18, 20 and 32 fingers have been used and finding an optimum RAKE receiver finger number has been targeted. First arm is locked to the first multipath component, m_1 . Multipath component, m_2 arrives τ_1 time units later than m_1 and is captured and so on. All decision statistics are weighted by a weighting factor, α to form overall decision statistics. The signals are then integrated over the entire period. The integrated signal is then compared with the appropriate threshold value to receive the better estimate of the transmitted signal. Since one pulse per bit of information transmitted is used all through, any of hard decision detection (HDD) or soft decision detection (SDD) can be used at the receiver, however, HDD has been adopted in this paper with TH-PPM UWB systems.

4. RAKE receiver principles

The goal of a RAKE receiver is to combine the energies of the useful signal components. Unfortunately, as a typical UWB channel has hundreds of resolvable paths, too many fingers would be necessary to capture all these energies. In practice, power consumption and channel estimation issues limit the number of fingers to ten or so. This prompts the notion of SRAKE [5], in which only the strongest paths are exploited. On the other hand, an ideal RAKE (ARAKE) is an ideal receiver in which all the non-zero resolvable multipaths are combined. Its performance establishes a benchmark for comparison of practical receivers. The operating principle of an SRAKE is as follows. Let $\{\alpha_q\}_{q=1}^Q$ be the gains of Q strongest paths and $\{\tau_q\}_{q=1}^Q$ the corresponding delays. Also let us assume that the receiver achieved perfect symbol synchronization for the desired signal. Then according to [4] the decision statistic for

the symbol a_i is a weighted sum of the type (maximum ratio combining):

$$x_i = \sum_{q=1}^Q \hat{\alpha}_q \int_{iN_f T_f}^{(i+1)N_f T_f} r(t) v(t - iN_f T_f - \hat{\tau}_q) dt, \quad (7)$$

where $\{\hat{\alpha}_q\}$ and $\{\hat{\tau}_q\}$ are the gain and delay estimates and $v(t)$ is a correlation template waveform depending on the signaling format, which for TH-PPM case, can be expressed as

$$v(t) = w_{lr}(t) - w_{lr}(t - \Delta). \quad (8)$$

With TH-PPM a decision $\hat{a} = 0$ or $\hat{a}_i = 1$ is made according to whether x_i is positive or negative, respectively, the corresponding decision being $\hat{a}_i = 1$ or $\hat{a}_i = -1$.

The channel impulse response (CIR) is assumed to be known. The total number of non-zero multipath components is found. In the case of ARAKE, all of the non-zero multipath components of CIR vector are considered with equal weight for the weighting factor vector, whereas for SRAKE a predefined number of weighting coefficients are considered in the descending order of their magnitude and the weighting factor vector is formed giving weight proportional to the magnitude of the respective multipath component. On the other hand, in the case of PRAKE receivers, a predefined number of multipath components are considered according to their propagation delay, i.e., on first receive first take basis and not on the basis of descending order of the magnitude as in SRAKE.

5. Results

The bit error rate (BER) performance of UWB system varies significantly as the number of fingers of RAKE receiver in use varies, as shown in this paper in case of TH-PPM UWB system using IEEE 802.15.3a UWB channel

Table 3
Equivalence of PRAKE fingers at BER = 10^{-1}

No. of multi-users	CM-3		CM-1	
	SRAKE	Eqv. PRAKE	SRAKE	Eqv. PRAKE
0, i.e., single user	2	8	2	4
	4	12	4	10
	8	20	8	14
	16	32	16	16
5	2	8	2	6
	4	12	4	8
	8	20	8	14
	16	32	16	20
10	2	8	2	6
	4	12	4	8
	8	18	8	14
	16	32	16	20
20	2	8	2	6
	4	14	4	10
	8	20	8	14
	16	32	16	20

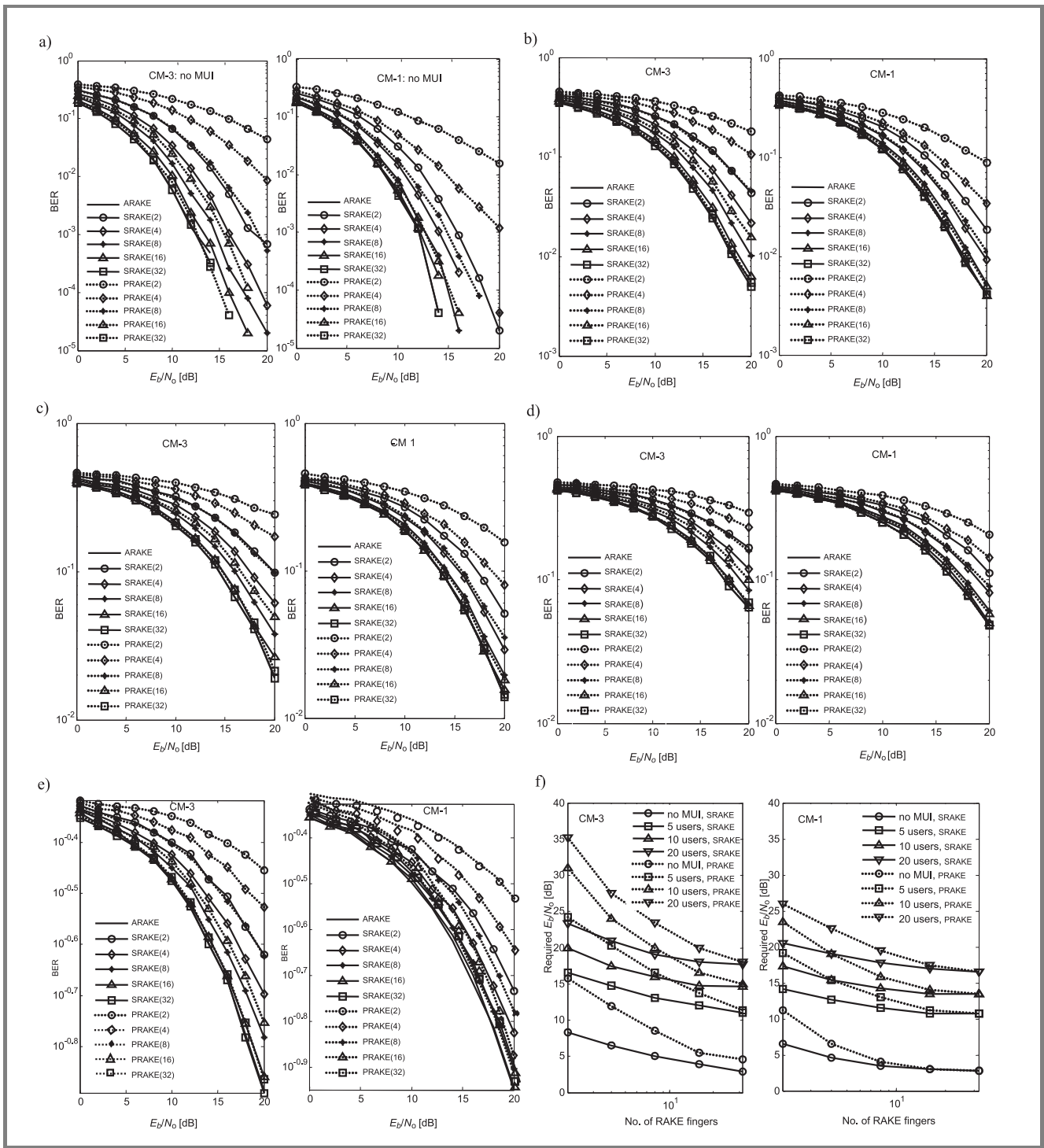

Fig. 5. Performance of TH-PPM UWB system under different multiple user scenarios: (a) single user; (b) 5; (c) 10; (d) 20; (e) 40 interfering users; (f) required SNR characteristics at desired BER of 10^{-1} .

model. In this paper, the equivalence of selective and partial RAKE finger performance has been investigated. As shown in Table 3, for a SRAKE receiver of 2 fingers, for a desired BER of 10^{-1} , as many as 8 PRAKE fingers are needed to achieve the same signal to noise ratio (SNR) requirement at all MUI scenarios. This implies that 4 times

as many as SRAKE fingers are needed if PRAKE receiver is used. However, if the number of available SRAKE arms is doubled to 4, 8, 16 it has been found that the equivalent PRAKE arm number required to give the same performance as that of corresponding SRAKE receiver becomes 3, 2.5 and 2 times as many as the SRAKE fingers on an average,

Table 4
SNR gains at different MUI scenarios for variation of RAKE fingers

No. of multi users	CM-3				CM-1					
	SRAKE		PRAKE		SRAKE		PRAKE			
	SNR gain [dB/octave]	No. of fingers, N_f	SNR gain [dB/octave]	No. of fingers, N_f	SNR gain [dB/octave]	No. of fingers, N_f	SNR gain [dB/octave]	No. of fingers, N_f		
0, i.e., single user	1.25	$2 \leq N_f \leq 32$	3.43	$2 \leq N_f \leq 16$	0.94	$2 \leq N_f \leq 32$	3.43	$2 \leq N_f \leq 8$		
			1.5	$16 \leq N_f \leq 32$			1.1	$8 \leq N_f \leq 32$		
5	1.75	$2 \leq N_f \leq 8$	3.8	$2 \leq N_f \leq 8$	1.17	$2 \leq N_f \leq 16$	3.8	$2 \leq N_f \leq 4$		
			2.64	$8 \leq N_f \leq 32$			0	$16 \leq N_f \leq 32$	2.08	$4 \leq N_f \leq 16$
10	1	$8 \leq N_f \leq 32$	0.55	$16 \leq N_f \leq 32$	1.9	$2 \leq N_f \leq 4$	3.85	$2 \leq N_f \leq 8$		
			2.5	$2 \leq N_f \leq 4$			0.95	$4 \leq N_f \leq 16$	1.2	$8 \leq N_f \leq 32$
			1.4	$4 \leq N_f \leq 16$			0.06	$16 \leq N_f \leq 32$		
20	0.14	$16 \leq N_f \leq 32$	1.5	$16 \leq N_f \leq 32$	1.17	$4 \leq N_f \leq 16$	3.25	$2 \leq N_f \leq 8$		
			2.15	$2 \leq N_f \leq 8$			0.44	$16 \leq N_f \leq 32$	1.47	$8 \leq N_f \leq 32$
			0.67	$8 \leq N_f \leq 32$			2	$16 \leq N_f \leq 32$		

respectively, in all MUI scenarios. It is found that increasing multiple users does not affect the ratio of SRAKE to equivalent PRAKE arms for a required SNR, although as shown in Fig. 5, the BER performance degrades severely if the number of multiple users increases. Figures 5a to 5e show the BER performances of the simulated TH-PPM system for different MUI scenarios for CM-3 and CM-1 cases of IEEE 802.15.3a UWB indoor channel model.

On the other hand, Fig. 5f shows the required SNR versus number of RAKE fingers characteristics at different MUI scenarios for a desired BER of 10^{-1} . Three things become clear from Fig. 5f. Firstly, increasing number of RAKE fingers requires comparatively less SNR in order to give the same bit error rate. This effect is desired and true for single user and multiple user scenarios. Secondly, increasing number of multiple users acting simultaneously implies a higher SNR requirement for the same bit error rate and for the same number of RAKE fingers used in the correlator receiver. Thirdly, as shown in Fig. 5f, the SNR requirement for SRAKE and PRAKE receivers changes at different fashions for different multiple user interference scenarios. For instance, as shown in Table 4, when 5 interfering users are present in the system, if the number of RAKE fingers is increased, SRAKE receiver provides an SNR gain at the rate of 1.75 dB/octave for up to 8 SRAKE fingers and 1 dB/octave from 8 fingers to 32 fingers, respectively, thus maintaining a two-slope straight-line relationship between required SNR and logarithm of SRAKE fingers. Whereas using PRAKE receiver we found a similar two-slope relationship but the required SNR decreases at the rates of 3.8 dB/octave and 2.64 dB/octave of the number of fin-

gers of the PRAKE receiver in the same range of PRAKE arms as is shown for SRAKE condition mentioned previously. Table 4 ultimately shows the different SNR gains as a function of SRAKE and PRAKE fingers, especially in presence of multiple user interference. The results for 40 multiple users is omitted here because the BER performance degrades enormously at that condition as shown in Fig. 5e.

As a final note, the BER performance and SNR gains of IEEE channel models, CM-3 and CM-1, have been compared with special focus on different multiple user interference scenarios. The discrete time channel impulse responses of CM-3 and CM-1 have been shown in Fig. 4. As shown in Fig. 5, for single user and with 5, 10, 20 and 40 interfering users transmitting simultaneously, the BER performances for CM-1 have found to be better than those for CM-3 case. This implies the fact that CM-1 is especially for short LOS distances of up to 2 m and CM-3 is for distances greater than 4 m. As shown in Table 3, in case of CM-1, the required number of PRAKE fingers equivalent to given SRAKE fingers is comparatively lower than that required for the corresponding CM-3 case. This is also due to the fact that CM-1 case has less number of significant multipath components than in CM-3, or alternatively, the rays of significant energy are more or less in the first set of rays for PRAKE receiver, which in fact reduces the performance gap between SRAKE and PRAKE receiver of the same number of fingers in CM-1 than in CM-3. Figure 4 shows that for CM-3 some rays with significant energy content can come after a long delay of, for instance, 50 ns. Referring to Table 4, it is found that in single user

case and also in the presence of 5, 10, 20 multiple users, CM-3 provides more SNR gains than in CM-1 case if the number of SRAKE or PRAKE fingers is doubled in 2, 4, 8, 16, 32 fashion. It is found as well in all simulation results that any type of RAKE receiver with 32 fingers would perform as good as an ideal RAKE which has a finger number equal to the number of non-zero multipaths in the system.

Finally, considering that increasing fingers would severely increase receiver complexity, using an SRAKE of 8 fingers has been recommended in this paper, making a trade-off among BER performance, SNR gain and circuit complexity.

6. Conclusions

In this paper the BER performances of TH-PPM UWB system using SRAKE and PRAKE receivers have been compared. Performances of two channel conditions named CM-1 and CM-3 of IEEE 802.15.3a model of UWB channel have been particularly investigated. ARAKE receiver performance is also shown for comparison of performances of SRAKE and PRAKE.

Results obtained through simulations show that the equivalent PRAKE finger number required for maintaining same SNR requirement varies from 2 to 3 times the original SRAKE fingers. Increasing multiple users deteriorates BER performance severely but has no effect on the ratio of the number of PRAKE fingers to that of SRAKE receiver. Results also suggest that with MUI the SNR gains due to increasing number of RAKE fingers for CM-3 channel model are different and are different from CM-1 condition, the gains for CM-1 being slightly lower than those for CM-3. Using a maximum of 32 RAKE fingers, regardless of being of SRAKE or PRAKE type, the ARAKE performance can be achieved. Finally, it is recommended that the number of SRAKE fingers must be limited to 8–10 for getting realistically optimum BER performance.

References

- [1] M.-G. Di Benedetto and G. Giancola, *Understanding Ultra Wide Band Radio Fundamentals*. First Edition. Upper Saddle River: Prentice Hall, 2004.
- [2] D. Barras, F. Ellinger, and H. Jäckel, "A comparison between ultra-wideband and narrowband transceivers", in *IEEE Wirel. 2002 Conf.*, Calgary, Canada, 2002.
- [3] M. Z. Win and R. A. Scholtz, "Ultra-wide bandwidth time hopping spread spectrum impulse radio for wireless multiple access communications", *IEEE Trans. Commun.*, vol. 48, pp. 679–691, 2000.
- [4] A. A. D'Amico, U. Mengali, and L. Taponecco, "Performance comparisons between two signaling formats for UWB communications", in *Proc. IEEE Int. Conf. Commun. ICC'04*, Paris, France, 2004.
- [5] D. Cassioli, M. Z. Win, F. Vatalaro, and A. F. Molish, "Performance of low-complexity Rake reception in a realistic UWB channel", in *Proc. IEEE Int. Conf. Commun. ICC'02*, New York, USA, 2002, pp. 763–767.

- [6] "IEEE Standard for Information technology – Telecommunications and information exchange between systems – Local and metropolitan area networks – Specific requirements". Part 15.3: "Wireless Medium Access Control (MAC) and Physical Layer (PHY) Specifications for High Rate Wireless Personal Area Networks (WPANs)", IEEE Std 802.15.3™-2003.
- [7] J. R. Foerster, M. Pendergrass, and A. F. Molisch, "A channel model for ultrawideband indoor communication", in *Proc. Wirel. Pers. Multimed. Commun. WPMC'03*, Kanagawa, Japan, 2003, vol. 2, pp. 116–120.
- [8] H. Sheng, P. Orlik, A. M. Haimovich, L. J. Cimini Jr., and J. Zhang, "On the spectral and power requirements for ultra-wideband transmission", in *Proc. IEEE Int. Conf. Commun. ICC'03*, Anchorage, USA, 2003, pp. 738–742.



Mohammad Upal Mahfuz received his B.Sc. engineering degree in electrical and electronic engineering from Bangladesh University of Engineering and Technology (BUET), Dhaka, Bangladesh, in 2002 and Master of engineering degree in telecommunications from Asian Institute of Technology (AIT), Thailand, in 2005. Currently, he

is working towards his doctorate degree at University of Calgary, Canada. His current research interests include ultra wideband wireless communications, mobile communications and satellite-based positioning and navigation systems.

e-mail: upal41@yahoo.com
Telecommunications Program
Asian Institute of Technology (AIT)
PO Box: 4, Khlongluang
Pathumthani 12120, Thailand



Kazi M. Ahmed received the M.Sc. Eng. degree in electrical engineering from the Institute of Communications, Leningrad, USSR, and the Ph.D. degree from the University of Newcastle, NSW, Australia, in 1978 and 1983, respectively. Currently, he is a Professor of telecommunications in the School of Engineering and

Technology, Asian Institute of Technology, Pathumthani, Thailand. His current research interests include digital signal processing, antenna array processing, tropospheric and ionospheric propagation studies for microwave, very high frequency-ultra high frequency communications, and satellite communications.

e-mail: kahmed@ait.ac.th
Telecommunications Program
Asian Institute of Technology (AIT)
PO Box: 4, Khlongluang
Pathumthani 12120, Thailand



Nandana Rajatheva received the B.Sc. degree in electronic and telecommunication engineering (with first class honors) from the University of Moratuwa, Sri Lanka, and the M.Sc. and Ph.D. degrees from the University of Manitoba, Winnipeg, Canada, in 1987, 1991, and 1995, respectively. Currently, he is an Associate

Professor of telecommunications in the School of Engineering and Technology, Asian Institute of Technology,

Pathumthani, Thailand. Earlier, he was with the University of Moratuwa, Sri Lanka, where he became a Professor of electronic and telecommunication engineering in June 2003. From May 1996 to December 2001, he was with TC-SAT as an Associate Professor. His research interests include mobile and wireless communications, coding and modulation techniques, space time processing for multiple input-multiple output systems, and communication theory. e-mail: rajath@ait.ac.th

Telecommunications Program
Asian Institute of Technology (AIT)
PO Box: 4, Khlongluang
Pathumthani 12120, Thailand